



**THERMO KING**

# Installation Manual

## **Trailer Edition Precedent™ C-600, S-600, and S-700 Single Temperature Systems**

Includes Rail Ready (RR) options for Domestic Refrigerated Containers (DRC) and Rail Box Car (RBC) applications.

Revision D

May 2018

**TK 55496-2-IM-EN**



## Introduction

This manual was written to assist with the installation of the Thermo King Precedent refrigeration systems onto trailers, Domestic Refrigerated Containers (DRC) and Rail Box Cars (RBC) specifically designed and built for refrigerated applications.

Due to its complexity, you should not attempt this installation unless you:

- Are an experienced mechanic
- Can safely lift 34 kilos (75 lbs.)
- Are certified or trained in the repair and maintenance of diesel powered refrigeration systems
- Have a basic understanding of electricity and electrical wiring
- Have the necessary tools and equipment to complete the installation

This manual is published for informational purposes only. Thermo King makes no representations warranties express or implied, with respect to the information recommendations and descriptions contained herein. Information provided should not be regarded as all-inclusive or covering all contingencies. If further information is required, Thermo King Corporation Service Department should be consulted.

**Thermo King's warranty shall not apply to any equipment which has been "so installed, maintained, repaired or altered as, in the manufacturer's judgment, to affect its integrity."**

***Manufacturer shall have no liability to any person or entity for any personal injury, property damage or any other direct, indirect, special, or consequential damages whatsoever, arising out of the use of this manual or any information, recommendations or descriptions contained herein. The procedures described herein should only be undertaken by suitably qualified personnel. Failure to implement these procedures correctly may cause damage to the Thermo King unit or other property or personal injury.***

## Revision History

Revision A	(05/15) Released new manual format.
Revision B	(07/15) Pages 42-43: corrected battery cable installation procedures to comply with industry standards; Page 51: added important information regarding disabling Eco Pulldown Mode during engine break-in procedures.
Revision C	(12/15) Added Rail Ready (RR) information.
Revision D	(05/18) General update of manual including new door latches and factory installed fuel pump and harness.



## Table of Contents

Safety Precautions.....	6
Danger, Warning, Caution, and Notice .....	6
General Practices .....	6
Battery Installation and Cable Routing .....	7
Refrigerant Hazards .....	8
Refrigerant Oil Hazards.....	8
First Aid.....	8
Installation Summary.....	10
Trailer Requirements .....	12
Front Wall Requirements .....	12
Unit Mounting Hardware .....	12
Unit Dimensions.....	12
Fuel Tank Mounting.....	12
King Pin Dimensions .....	12
Swing Radius Clearance.....	13
Swing Radius and King Pin Requirements .....	14
Evaporator Opening Requirements .....	16
Mounting Hardware Requirements .....	18
Mounting Bolts .....	18
Mounting Bolt Specifications .....	18
Unit Dimensions.....	20
Battery Selection Guide.....	24
Lifting Bar Dimensions .....	26
Required Tools for Installation.....	28
Installation Components – Trailer Applications .....	29
Installation Components – RBC Applications.....	30
Installation Components – DRC Applications .....	31
Unpacking the Unit .....	32
Installing the Heat Shield .....	33
Installing the Unit.....	34
Unit Installation.....	34
Access to Mounting Bolts.....	34



Installing the Drain Hoses and Coolant Overflow Hose – Trailer Applications .....	36
Evaporator Drain and Overflow Hose Installation .....	36
Installing Drain Hoses and Coolant Overflow Hose – DRC and RBC Applications .....	37
Drain and Overflow Hose Installation .....	37
Installing the Fuel Lines – Trailer Applications .....	38
Important Installation Requirements .....	38
Fuel System Fittings .....	38
Fuel Line Installation .....	38
Installing the UFLS Harness – Trailer Applications .....	40
“Solid State” Ultrasonic Fuel Level Sensor (UFLS) .....	40
Interconnect Harness Installation and Routing .....	40
UFLS Harness Connections .....	40
Installing the Float Style Fuel Level Sensor Harness – DRC and RBC Applications .....	42
Wire Routing and Connections .....	42
Installing the Power Receptacle (Option) – Trailer Applications .....	44
Installing the LED Clearance Lighting (Option) – Trailer Applications .....	45
Installing the Battery .....	46
Installing the Top Covers and Bottom Pan – Trailer Applications .....	48
Installing the Top Covers and Bottom Pan – DRC and RBC Applications .....	50
Installing the Fuel Lines – DRC and RBC Applications .....	52
Important Installation Requirements .....	52
Fuel System Fittings .....	52
Fuel Line Installation .....	52
Installing the Exhaust Pipe Extension – DRC Applications Only .....	54
Operating the Unit .....	56
High Voltage Safety Precautions .....	56
High Voltage Components .....	56
Unit Fan Operation Safety Precautions .....	56
Condenser and Evaporator Fans .....	56

Priming the Fuel Pump .....	58
Programming the Controller .....	59
Programming the SR-4 Controller for Fuel Level .....	59
UNIT CHECK LIST .....	60

# Safety Precautions

## Danger, Warning, Caution, and Notice

Thermo King recommends that all service be performed by a Thermo King dealer and to be aware of several general safety practices.

Safety advisories appear throughout this manual as required. Your personal safety and the proper installation of this unit depend upon the strict observance of these precautions.

**⚠ DANGER**

Indicates an imminently hazardous situation which, if not avoided, will result in death or serious injury.

**⚠ WARNING**

Indicates a potentially hazardous situation which, if not avoided, could result in death or serious injury.

**⚠ CAUTION**

Indicates a potentially hazardous situation which, if not avoided, could result in minor or moderate injury and unsafe practices.

**NOTICE**

Indicates a situation that could result in equipment or property-damage only accidents.

## General Practices

**⚠ DANGER****Hazardous Voltage!**

Dangerous three phase AC electric power is present whenever the unit is operating in either Diesel Mode or Electric Mode and whenever the unit is connected to a source of external standby power. Voltages of this magnitude can be lethal. Exercise extreme caution when working on the unit.

**⚠ DANGER****Hazard of Explosion!**

Never apply heat to a sealed refrigeration system or container. Heat increases internal pressure, which might cause an explosion resulting in death or serious injury.

**⚠ DANGER****Hazardous Gases!**

Refrigerant in the presence of an open flame, spark, or electrical short produces toxic gases that are severe respiratory irritants which can cause serious injury or possible death.

**⚠ DANGER****Refrigerant Vapor Hazard!**

Do not inhale refrigerant. Use caution when working with refrigerant or a refrigeration system in any confined area with a limited air supply. Refrigerant displaces air and can cause oxygen depletion, resulting in suffocation and possible death.

**⚠ DANGER****Risk of Injury!**

Keep your hands, clothing, and tools clear of fans and/or belts when working on a unit that is running or when opening or closing compressor service valves. Loose clothing might entangle moving pulleys or belts, causing serious injury or possible death.

**⚠ WARNING****Hazard of Explosion!**

Never close the compressor discharge service valve when the unit is operating. Never operate the unit with the discharge valve closed (front seated). This condition increases internal pressure, which can cause an explosion.

**⚠ WARNING****Personal Protective Equipment (PPE) Required!**

Always wear goggles or safety glasses when working on a unit. Refrigerant liquid, oil, and battery acid can permanently damage your eyes. See "First Aid".

**⚠ WARNING****Equipment Damage and Risk of Injury!**

Never drill holes into the unit unless instructed by Thermo King. Holes drilled into high voltage cables could cause an electrical fire, severe personal injury, or even death.

**⚠ WARNING****Risk of Injury!**

When using ladders to install or service refrigeration systems, always observe the ladder manufacturer's safety labels and warnings. A work platform or scaffolding is the recommended method for installations and servicing.

**NOTICE****Equipment Damage!**

All mounting bolts must be tight and are the correct length for their applications. Improper torque and incorrect bolt lengths can damage equipment.

## Battery Installation and Cable Routing

**⚠ WARNING****Hazard of Explosion!**

An improperly installed battery could result in a fire, explosion, or injury. A Thermo King approved battery must be installed and properly secured to the battery tray.

**⚠ WARNING****Hazard of Explosion!**

Improperly installed battery cables could result in a fire, explosion, or injury. Battery cables must be installed, routed, and secured properly to prevent them from rubbing, chaffing, or making contact with hot, sharp, or rotating components.

**⚠ WARNING****Fire Hazard!**

Do not attach fuel lines to battery cables or electrical harnesses. This has the potential to cause a fire and could cause serious injury or death.



### ⚠ WARNING

#### Hazard of Explosion!

Always cover battery terminals to prevent them from making contact with metal components during battery installation. Battery terminals grounding against metal could cause the battery to explode.

### ⚠ CAUTION

#### Hazardous Service Procedures!

Set all unit electrical controls to the OFF position before connecting battery cables to the battery to prevent unit from starting unexpectedly and causing personal injury.

### NOTICE

#### Equipment Damage!

Do not connect other manufacturer's equipment to the unit unless approved by Thermo King. Failure to do so can result in severe damage to equipment and void the warranty.

## Refrigerant Hazards

### ⚠ WARNING

#### Personal Protective Equipment (PPE) Required!

Refrigerant in a liquid state evaporates rapidly when exposed to the atmosphere, freezing anything it contacts. Wear butyl lined gloves and other clothing and eye wear when handling refrigerant to help prevent frostbite.

## Refrigerant Oil Hazards

### ⚠ WARNING

#### Personal Protective Equipment (PPE) Required!

Protect your eyes from contact with refrigerant oil. The oil can cause serious eye injuries. Protect skin and clothing from prolonged or repeated contact with refrigerant oil. To prevent irritation, wash your hands and clothing thoroughly after handling the oil. Rubber gloves are recommended.

## First Aid

### REFRIGERANT

- **Eyes:** For contact with liquid, immediately flush eyes with large amounts of water and get prompt medical attention.
- **Skin:** Flush area with large amounts of warm water. Do not apply heat. Remove contaminated clothing and shoes. Wrap burns with dry, sterile, bulky dressing to protect from infection. Get prompt medical attention. Wash contaminated clothing before reuse.
- **Inhalation:** Move victim to fresh air and use CPR (cardio pulmonary resuscitation) or mouth-to-mouth resuscitation to restore breathing, if necessary. Stay with victim until emergency personnel arrive.
- **Frost Bite:** In the event of frost bite, the objectives of First Aid are to protect the frozen area from further injury, warm the affected area rapidly, and to maintain respiration.

### REFRIGERANT OIL

- **Eyes:** Immediately flush with large amounts of water for at least 15 minutes. Get prompt medical attention.



- **Skin:** Remove contaminated clothing. Wash thoroughly with soap and water. Get medical attention if irritation persists.
- **Inhalation:** Move victim to fresh air and use CPR (cardio pulmonary resuscitation) or mouth-to-mouth resuscitation to restore breathing, if necessary. Stay with victim until emergency personnel arrive.
- **Ingestion:** Do not induce vomiting. Immediately contact local poison control center or physician.

**ENGINE COOLANT**

- **Eyes:** Immediately flush with large amounts of water for at least 15 minutes. Get prompt medical attention.
- **Skin:** Remove contaminated clothing. Wash thoroughly with soap and water. Get medical attention if irritation persists.
- **Ingestion:** Do not induce vomiting. Immediately contact local poison control center or physician.

**ELECTRICAL SHOCK**

Take IMMEDIATE action after a person has received an electrical shock. Get quick medical assistance, if possible.

The source of the shock must be quickly stopped, by either shutting off the power or removing the victim. If the power cannot be shut off, the wire should be cut with a non-conductive tool, such as a wood-handle axe or thickly insulated cable cutters. Rescuers should wear insulated gloves and safety glasses, and avoid looking at wires being cut. The ensuing flash can cause burns and blindness.

If the victim must be removed from a live circuit, pull the victim away with a non-conductive material. Use wood, rope, a belt or coat to pull or push the victim away from the current. DO NOT TOUCH the victim. You will receive a shock from current flowing through the victim's body. After separating the victim from power source, immediately check for signs of a pulse and respiration. If no pulse is present, start CPR (cardio pulmonary resuscitation). If a pulse is present, respiration might be restored by using mouth-to-mouth resuscitation. Call for emergency medical assistance.

# Installation Summary

Precedent installs the same as a SB unit with the following exceptions:

1. The Precedent unit is approximately 152.4 mm (6.00 in) wider than a SB which may interfere with trailer mounted fresh air exchange doors. See *“Evaporator Opening Requirements,” p. 16.*
2. Evaporator opening and mounting bolt locations on front wall of trailer did not change. However, two particular mounting bolts should be trimmed to 2.25 to 2.50 inches in length from the surface of the trailer wall. All other bolts should be trimmed to 2.25 to 2.75 inches in length from the surface of the trailer wall. See *“Mounting Hardware Requirements,” p. 18.*
3. Overall unit height may be different depending on the application. Domestic Refrigerated Containers (DRC) and Trailer On Flat Car (TOFC) with an intermodal guard applications do not have a top fairing. See *“Unit Dimensions,” p. 20.*
4. Unit door opening radius may be different depending on the application. Domestic Refrigerated Containers (DRC) and Trailer On Flat Car (TOFC) with an intermodal guard applications will have reduced door opening radius. See *“Unit Dimensions,” p. 20.*
5. A new two point lifting bar is required to safely lift unit during installation. See *“Lifting Bar Dimensions,” p. 26.*
6. The supplied heat shield must be installed onto front wall of trailer prior to unit installation. See *“Installing the Heat Shield,” p. 33.*
7. **IMPORTANT: Using the wrong fuel system fittings may void your engine warranty! All Thermo King supplied fuel line fittings (except fuel line connector) are nickel plated brass for Precedent units.**

**DO NOT use fuel fittings (main body) made of brass, copper, zinc, zinc plated or galvanized steel where it would make direct contact with flowing diesel fuel. Diesel fuel flowing through these types of fittings allows those metals to leach into the fuel forming deposits on the injector tips which fouls them prematurely.**

**Fuel fitting nuts, compression sleeves, and fuel line connectors made of brass are acceptable because diesel fuel does not flow across their surfaces.**

- **DO NOT use PTFE (Polytetrafluoroethylene) thread sealing tape on fuel fittings in a Precedent unit. PTFE tape may allow strands into the fuel system that could plug the tight clearance fuel injectors causing failures.**
- **DO NOT use a SB fuel tank with a Precedent unit as they may contain fittings made from brass, zinc plated or galvanized steel. Precedent specific fuel tanks have nickel plated brass fittings and an aluminum drain plug.**
- **IMPORTANT: The factory installed fuel tank air vent must be in place and functional for the Thermo King unit’s fuel system to operate correctly and for the fuel tank to remain in compliance with Federal Motor Carrier Safety Administration specifications (title 49, paragraph 393.67). A plugged or restricted fuel tank air vent can result in premature damage to the fuel pump and could also cause severe damage to the fuel tank. NEVER remove or install any other component in place of the fuel tank air vent.**

**Note:** Beginning 2nd quarter 2018, numerous changes were made to the fuel system that affects the installation. See items 8–12 below.

8. Fuel Pump — The fuel pump is now factory installed onto a bracket mounted inside the curbside of the unit.
9. Fuel Pump Harness — The fuel pump harness is now factory connected to the main harness with a 2-pin connector.

**Note:** The trailer’s conduit or chase previously used for the fuel pump harness will still be needed for the optional ultrasonic fuel level sensor (UFLS) harness.

10. Fuel Supply Line — 3/8" fuel supply line is now factory installed from the fuel pump outlet fitting up to the fuel filter. A 3/8" fuel supply line will still need to be installed from the fuel

pump inlet fitting to the fuel tank outlet fitting. **NOTE: Rail Ready units require drilling two holes and installing grommets into the bottom pan for fuel line routing.**

11. Fuel Return Line — The fuel return line has been changed from 1/4" to 3/8" except for DRC and RBC units. Fuel return line will still need to be installed from the fuel filter down to the fuel tank return fitting.
12. Fuel Tank — Both the fuel supply and return lines must now be installed 1.00" (25.4 mm) from the bottom of the fuel tank.
13. It is recommended the installer provide a separate conduit or chase under trailer with a minimum inside diameter of 25.4 mm (1.00 in.) to accommodate the ultrasonic fuel sensor harness. See *"Installing the UFLS Harness – Trailer Applications," p. 40.*
14. Ultrasonic Fuel Level Sensor harness supplied needs to be routed from fuel tank to bottom of unit through conduit or chase. Harness needs to be attached to wires provided inside control box and to sensor at tank using supplied butt splice connectors and heat shrink. Six connections total. See *"Installing the UFLS Harness – Trailer Applications," p. 40.*
15. SmartPower™ units come pre-wired with power cable and receptacle secured inside unit with tie bands for shipment. The installer will need to secure receptacle under roadside of unit with supplied hardware. Cable needs to be secured to trailer wall with supplied cable clamps and screws. See *"Installing the Power Receptacle (Option) – Trailer Applications," p. 44.* This does not apply to units with the Remote Receptacle option.
16. Battery installation requires removal of roadside door and a bracket to access battery tray and cables. See *"Installing the Battery," p. 46.*
17. Bottom panel and two top covers need to be installed with supplied hardware. **NOTE: Rail Ready units require drilling two holes and installing grommets into the bottom pan for fuel line routing.** The top fairing (if equipped) should be removed if it interferes with maximum trailer height restrictions. See *"Installing the Top Covers and Bottom Pan – Trailer Applications," p. 48.*
18. It may take a few attempts to start a newly installed unit for the first time as the fuel pump primes itself, fills the fuel lines and filter, and automatically bleeds air from the system. The fuel pump can also be primed separately by using the SR-4 Controller's Interface Board Test Mode - Run Relay Function. This function operates only the fuel pump and primes the fuel system without cranking the engine. See *"Priming the Fuel Pump," p. 58.*
19. IMPORTANT: ECO-Pulldown Mode must be disabled to allow the engine to run continuous high speed operation during engine break-in. See *"UNIT CHECK LIST," p. 60.*

## Trailer Requirements

### Approximate Weight of Precedent transport temperature control units:

C-600, S-600, and S-700 = 842 kg (1857 lbs.)  
with SmartPower™ 12 HP/230V = 946 kg (2086 lbs.)  
with SmartPower™ 12 HP/460V = 962 kg (2121 lbs.)  
with SmartPower™ 19 HP/460V = 962 kg (2121 lbs.)

### EVAPORATOR OPENING REQUIREMENTS

*Important:* The location of the evaporator opening in the front wall of the trailer is critical to the proper installation and operation of the Thermo King unit. See “Evaporator Opening Requirements,” p. 16.

## Front Wall Requirements

### ⚠ DANGER

#### Risk of Injury!

The front wall of the trailer must be structurally strong enough to support the weight of the refrigeration unit.

## Unit Mounting Hardware

### ⚠ DANGER

#### Risk of Injury!

The use of mounting hardware other than specified for installing the refrigeration unit could result in severe damage to equipment, void the warranty, or cause personal injury or death.

*Important:* The location of the unit mounting bolts in the front wall of the trailer is critical for proper unit installation. See “Mounting Hardware Requirements,” p. 18.

## Unit Dimensions

*Important:* Adequate clearance must be provided to allow for routine service and maintenance of the Thermo King unit. See “Unit Dimensions,” p. 20.

## Fuel Tank Mounting

### ⚠ DANGER

#### Risk of Injury!

An improperly installed fuel tank could lead to serious injury or death. Consult your trailer manufacturer for specific details on proper fuel tank installation and recommendations.

## King Pin Dimensions

### NOTICE

#### Equipment Damage!

The minimum distance from the king pin to the front of the trailer must be at least 609.6 mm (24.00 in.) or severe damage to the equipment will result. **VERIFY THIS DIMENSION BEFORE INSTALLING UNIT!** See “Swing Radius and King Pin Requirements”.

*Important:* **VERIFY THIS DIMENSION BEFORE INSTALLING THE UNIT.** See “Swing Radius and King Pin Requirements,” p. 14.

---

## Swing Radius Clearance

### **NOTICE**

#### **Equipment Damage!**

The minimum clearance required for the swing radius must be 1306.3 mm (51.43 in.) or severe damage to the equipment will result. **VERIFY THIS DIMENSION BEFORE INSTALLING UNIT!** See "Swing Radius and King Pin Requirements".

*Important: VERIFY THIS DIMENSION BEFORE INSTALLING THE UNIT. See "Swing Radius and King Pin Requirements," p. 14.*

## Swing Radius and King Pin Requirements

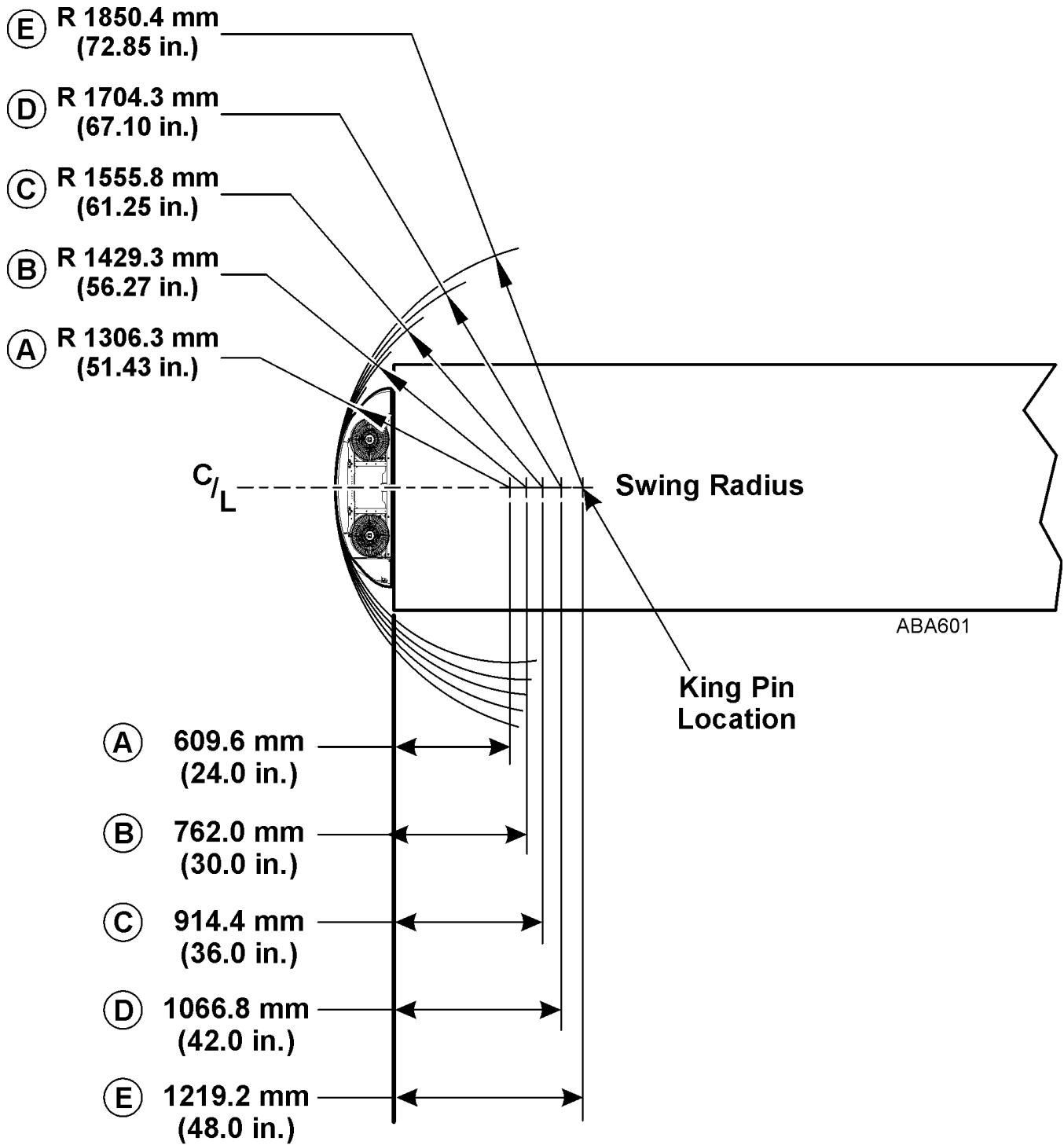



## Evaporator Opening Requirements

### **⚠ DANGER**

#### **Risk of Injury!**

The front wall of the trailer must be structurally strong enough to support the weight of the refrigeration unit.

**Important:** The location of the unit mounting bolts and evaporator opening in the front wall is critical. **VERIFY ALL DIMENSIONS BEFORE INSTALLING THE UNIT.**

**Note:** It may be necessary to relocate the trailer's front corner clearance lights to the corner radius of the trailer to prevent damage.

1. The evaporator opening must be square. The diagonal measurements must be  $\pm 3.0$  mm (0.12 in.).
2. The gasket surface around the opening must be at least 76.2 mm (3.00 in.) wide, be flat  $\pm 3.2$  mm (0.12 in.) and free of rivets, seams, or bolt heads.

**Note:** The Precedent unit is 152.4 mm (6.00 in.) wider than the SB. Verify adequate clearance is available for trailer fresh air exchange doors, if applicable. Thermo King fresh air exchange option 070026 is also available.

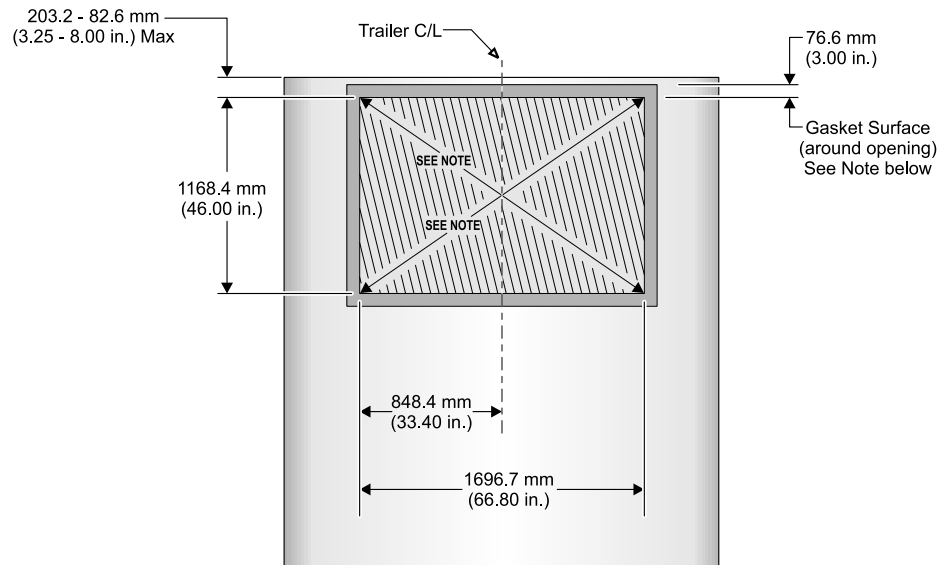

**EVAPORATOR OPENING REQUIREMENTS  
FRONT VIEW**

**NOTE:** Corners of Evaporator opening **MUST** be Square. The diagonal measurement must be within 3.2 mm (0.12 in.).

**NOTE:** Gasket Surface **must** be free of rivets, seams, & bolt heads

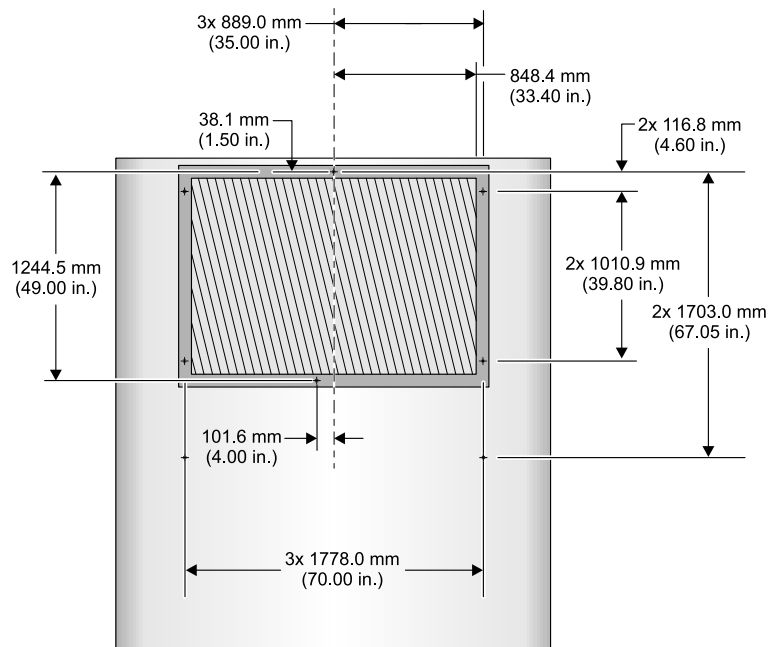
**UNIT MOUNTING BOLT LOCATIONS  
FRONT VIEW**

ABA281-1

# Mounting Hardware Requirements

## Mounting Bolts

### **⚠ DANGER**

#### **Risk of Injury!**

**Eight mounting bolts must be installed to properly secure the unit to the trailer front wall. Failure to do so could result in severe damage to equipment, void the warranty, or cause personal injury or death.**

*Note: The location of the unit mounting bolts in the trailer front wall is critical to proper unit installation.*

All mounting bolts must be square with the front wall and securely fastened to the trailer wall in such a manner to allow the mounting nuts be torqued to 82 N•m (60 ft. lbs.) from outside the trailer.

Refer to “[Evaporator Opening Requirements](#),” p. 16 regarding the following mounting bolt details:

- Surface of all mounting bolts are to be flat within 2.50 mm (0.10 in.).
- Six unit mounting bolts should be trimmed to extend a **minimum** 57.2 mm (2.25 in.) and a **maximum** of 69.8 mm (2.75 in.) beyond the surface of the front wall.
- Two unit mounting bolts should be trimmed to extend a **minimum** 57.2 mm (2.25 in.) and a **maximum** of 63.5 mm (2.50 in.) beyond the surface of the front wall.

## Mounting Bolt Specifications

### **⚠ DANGER**

#### **Risk of Injury!**

**The use of mounting bolts other than those specified could result in severe damage to equipment, void the warranty, or cause personal injury or death.**

Use 1/2 in.-13 UNC - 28 Rolled thread grade 5, medium carbon steel bolts and locking nuts. All hardware must be zinc plated with dichromate finish.

These six unit mounting bolts should be trimmed to extend a **minimum** 57.2 mm (2.25 in.) and a **maximum** of 69.8 mm (2.75 in.) beyond the surface of the front wall.

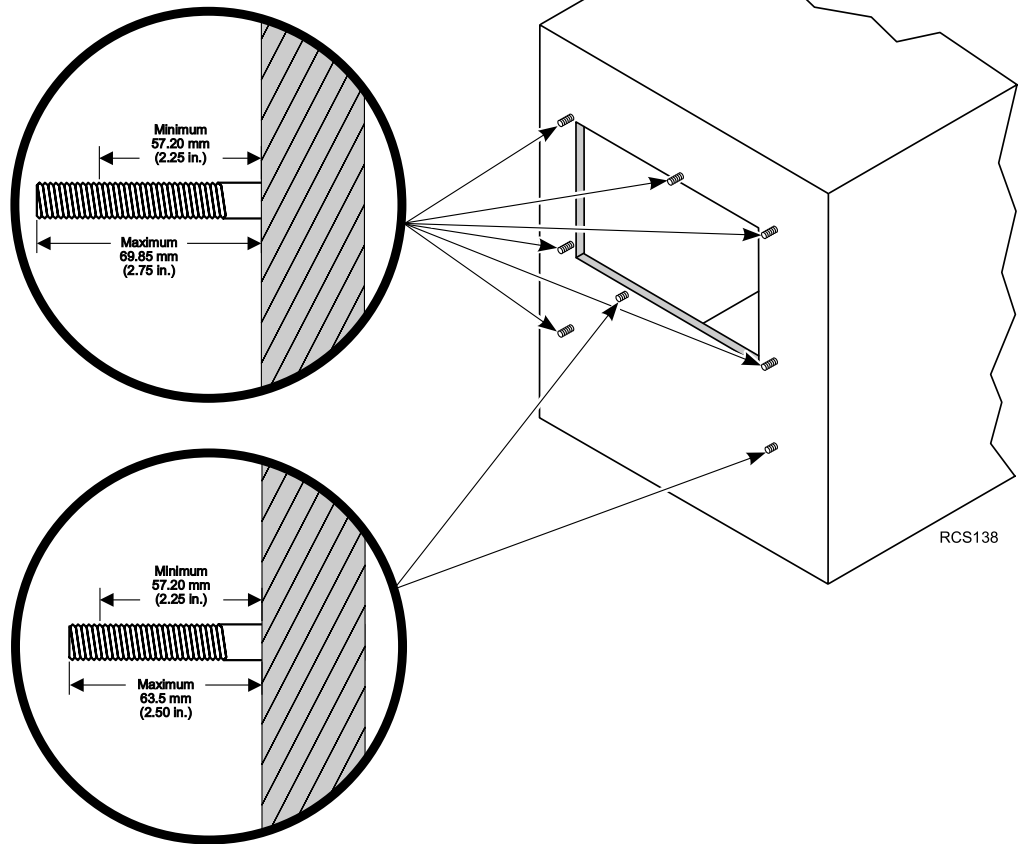

These two unit mounting bolts should be trimmed to extend a **minimum** 57.2 mm (2.25 in.) and a **maximum** of 63.5 mm (2.50 in.) beyond the surface of the front wall.

# Unit Dimensions

## FRONT VIEW

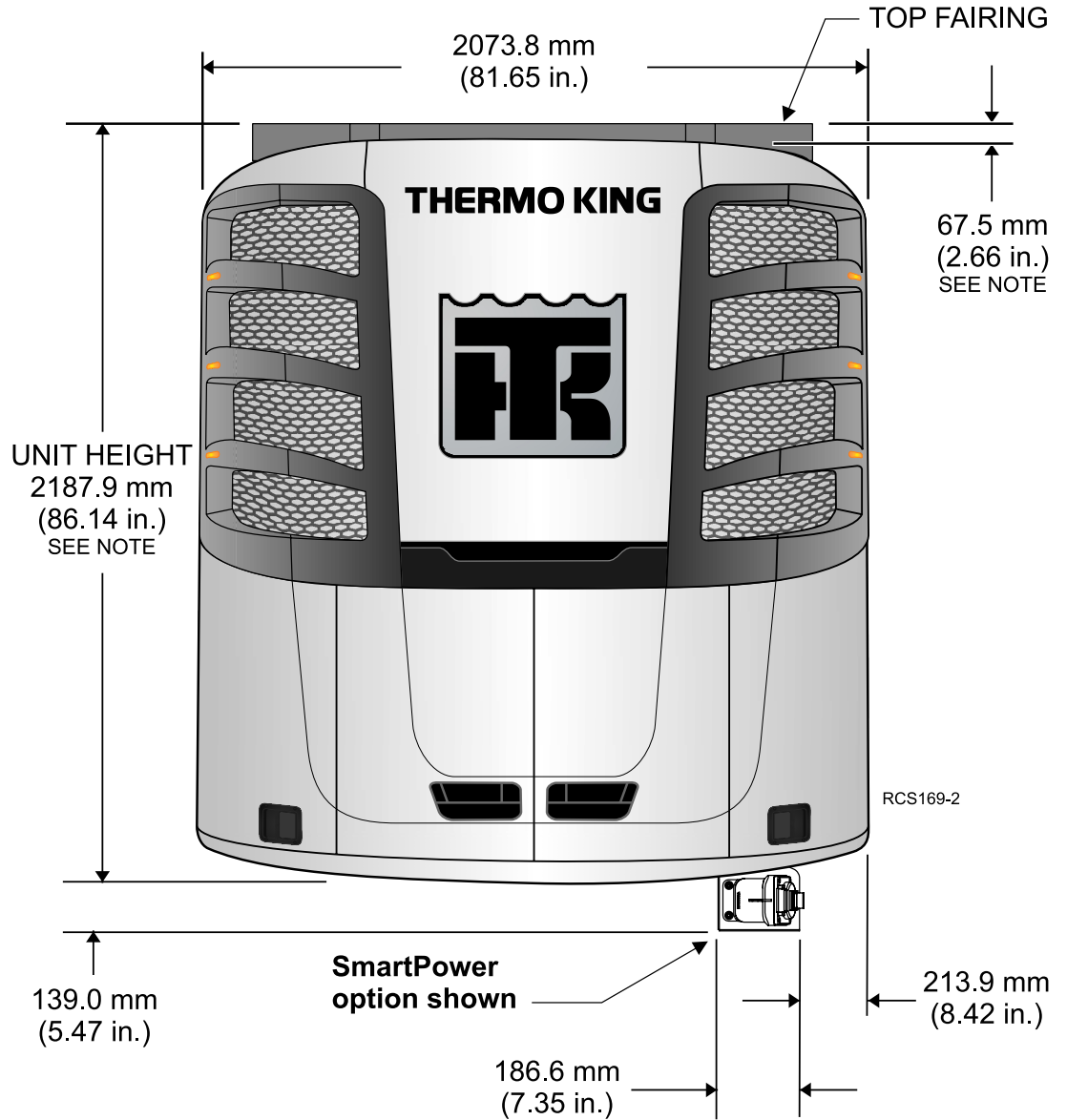

**NOTE:** The unit height shown includes the top fairing. Some applications such as Domestic Refrigerated Containers (DRC) and Trailer On Flat Car (TOFC) with an intermodal guard will not have a top fairing. The unit height for these applications would be 67.5 mm (2.66 in.) less.

**REAR VIEW**

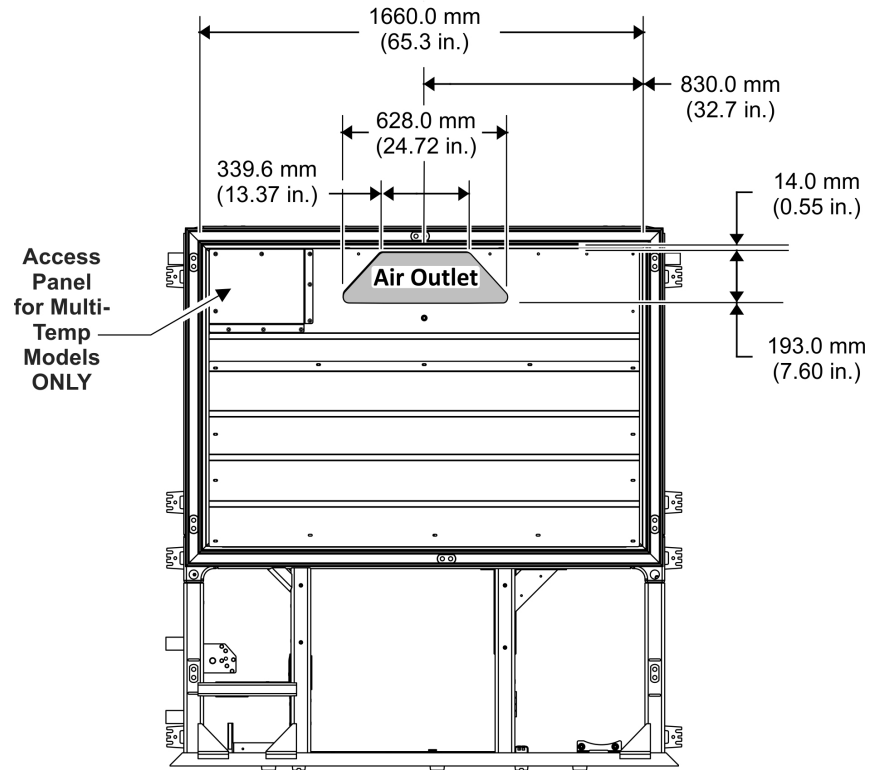

**REAR VIEW DE**

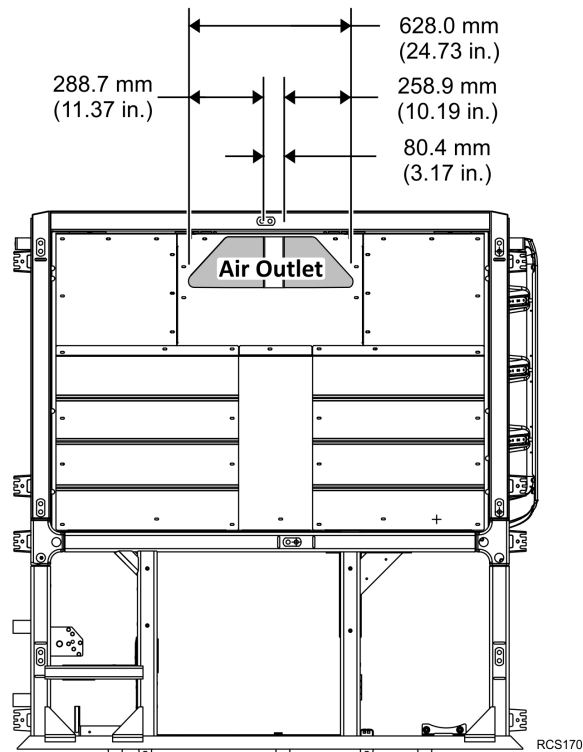

**TOP VIEW**  
UPPER GRILLE RADII

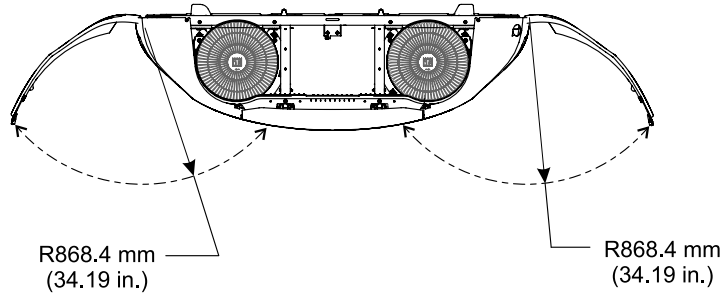

**TOP VIEW**  
LOWER DOOR & PANEL RADII

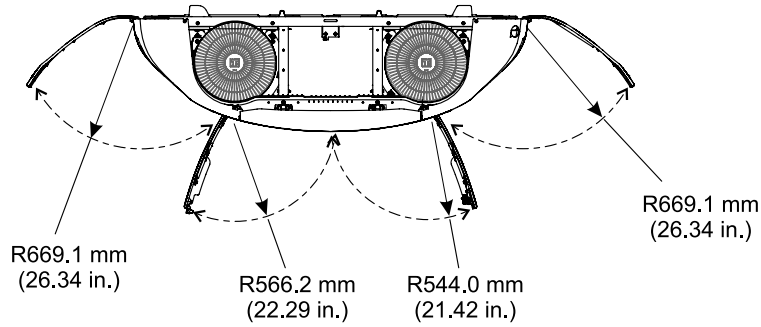

**SIDE VIEW**  
TOP DOOR RADIUS

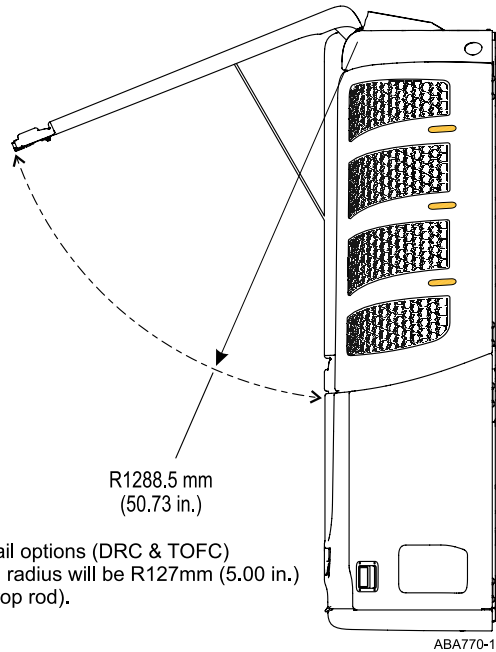

**NOTE:** For rail options (DRC & TOFC) door opening radius will be R127mm (5.00 in.) (with short prop rod).

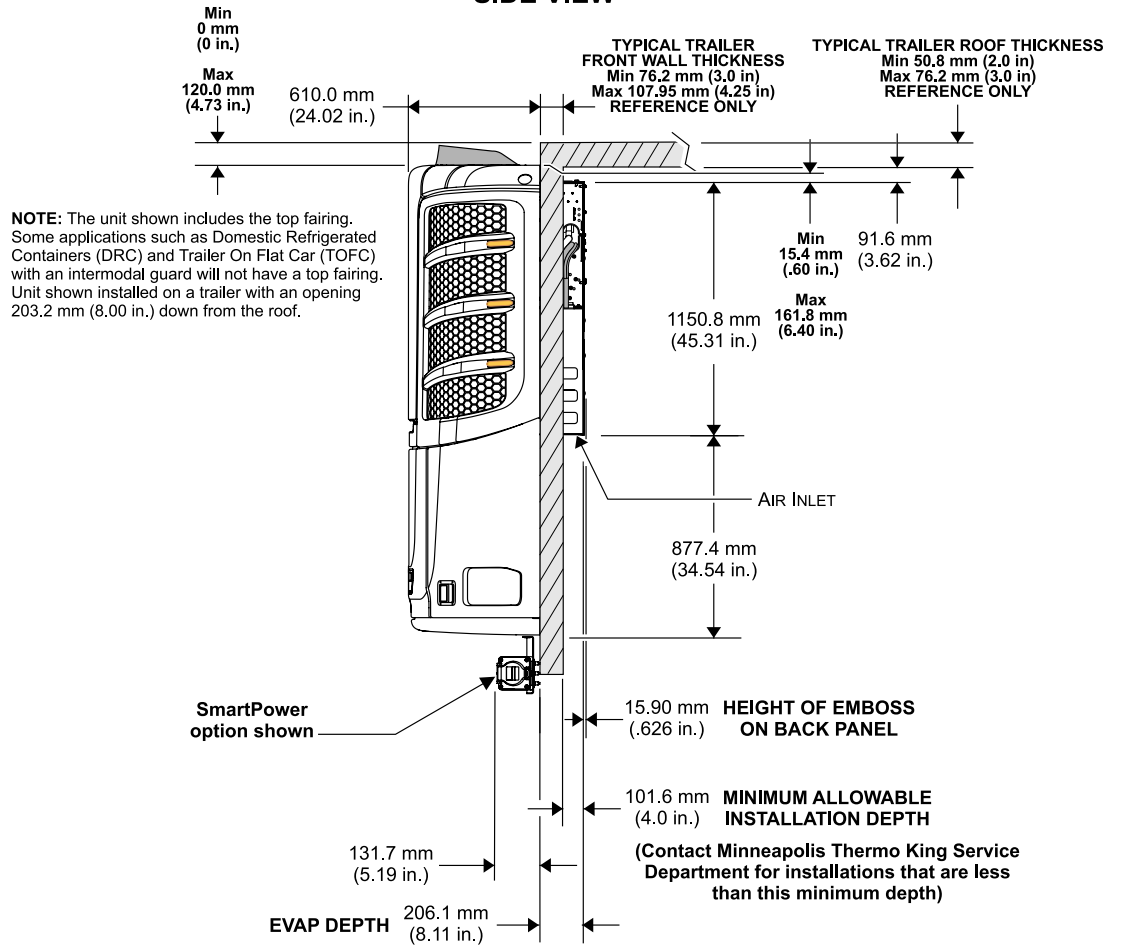
**SIDE VIEW**

ABA635-1

# Battery Selection Guide

## NOTICE

### Equipment Damage!

**Do not connect other manufacturer's equipment to the unit unless approved by Thermo King. Failure to do so can result in severe damage to equipment and void the warranty.**

***Important:** The specified battery, electrical wiring and electronic controls were designed to operate and maintain only the Thermo King refrigeration system and factory authorized Thermo King options.*

Trailer units are designed for one, Group C31,12 volt battery supplied by the installer.

The battery must be suitable for deep cycling, heavy duty and rated with a minimum of 95 amp/hr.

**Note:** See the following table for Thermo King approved batteries.

<b>BATTERY APPLICATION TABLE</b>	
925 CCA Wet Cell Thermo King ReliaMax 925N P/N 203-733 Threaded Stud P/N 203-732 SAE Post	1150 CCA Dry Cell (AGM) Thermo King EON P/N 203-550 Threaded Stud P/N 203-551 SAE Post
<ul style="list-style-type: none"> <li>Wet Cell Technology</li> <li>Recommended for both warm and cold climates</li> <li>High cranking power at low ambient temperatures</li> <li>18-24 month expected life *see note below</li> </ul>	<ul style="list-style-type: none"> <li>Dry Cell (AGM) Technology</li> <li>Recommended for extreme climates and for Rail Ready (RR), Domestic Refrigerated Container (DRC), and Trailer on Flat Car (TOFC) applications.</li> <li>High cranking power at lower ambient temperatures</li> <li>Suited for extreme temperatures</li> <li>Best for high cycling applications (Cycle-Sentry use)</li> <li>5-7 year expected life</li> </ul>
<p><small>* NOTE: Wet cell battery life and maintenance requirements are determined by the operating environment and the charge/discharge rate (cycles) while the battery is in service. Higher ambient temperatures and frequent discharges will shorten a wet cell battery's overall life expectancy and increase maintenance requirement. If the unit is not going to be used for an extended period of time, turn the Microprocessor On/Off Power Switch to the OFF position to maximize battery life.</small></p>	





# Lifting Bar Dimensions

**⚠ WARNING**

**Risk of Injury!**  
 Thermo King requires a 2 point lifting bar to safely lift and install units. A lifting bar can be made from the drawings provided using ASTM A514 Grade B Steel Plate (UNS K11630).

**⚠ WARNING**

**Risk of Injury!**  
 The lifting bar and lifting device combined must be able to support minimum weight of 1360.8 kilos (1 1/2 tons).

*Important: Use forged clevis and pins, forged chain links and forged eyebolts with strength equal to total lift capacity of hoist mechanism and that meet all safety standards.*

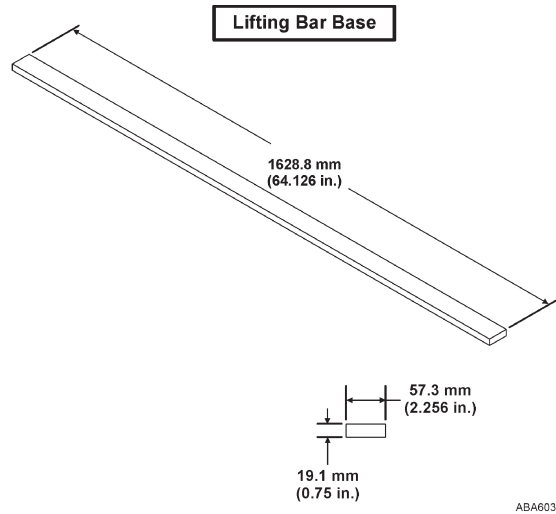
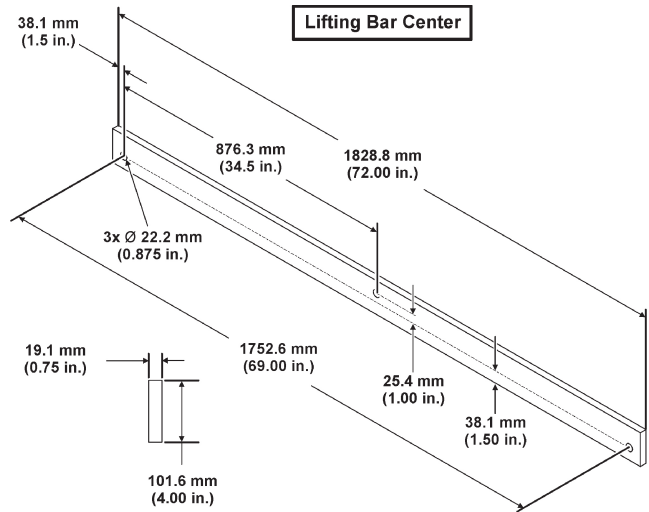

ABA603

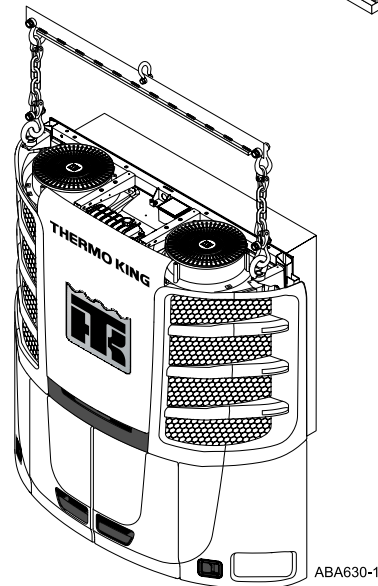
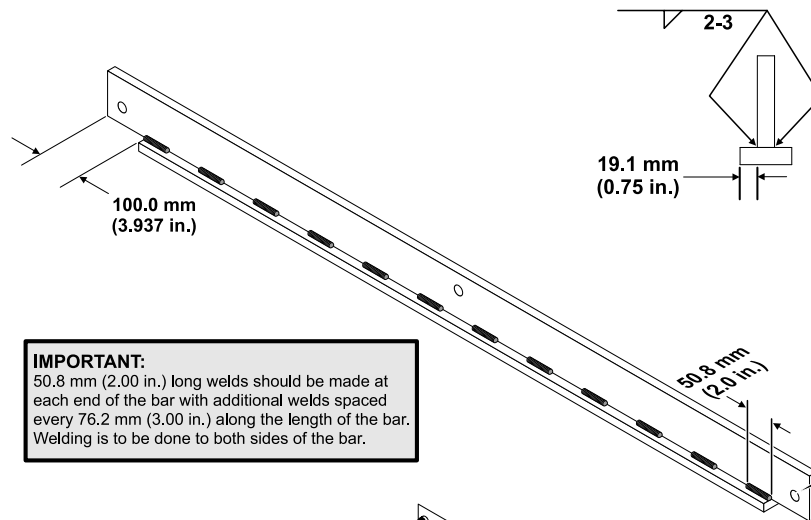
**Welded Lifting Bar Assembly**

1.	Forged Clevis Pins
2.	Forged Chain Links
3.	Forged Eyebolts

**Note:** These instructions are provided for fabricating the lifting bar used to install Precedent units. Thermo King is not the manufacturer of the lifting bar and is not responsible for material used or failure of this lifting device.

## Required Tools for Installation

1. Safety Glasses
2. Drill
3. Drill Bits
4. Tape Measure
5. Mechanics Tools
6. Lifting Bar
7. Work Platform (Recommended)
8. Torque Wrench
9. Forged Eyebolts (5/8–11)

**Note:** Equipment such as scales, gauges, refrigerant leak detectors, and torque wrenches should be in good working condition and routinely calibrated to assure accurate readings.

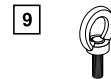
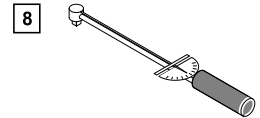
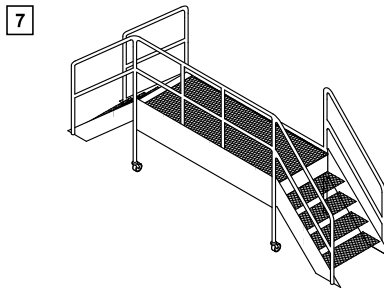
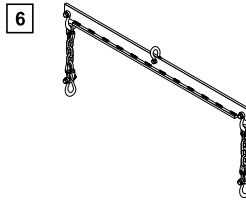
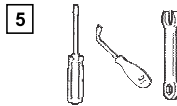
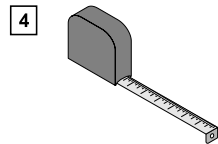
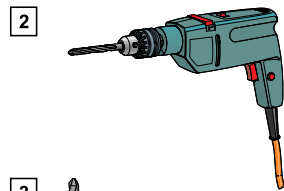

# Installation Components – Trailer Applications

**1** Unit Mounting Kit

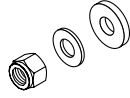

**2** Drain Tube Kit

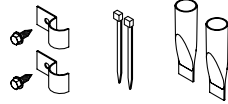

**3** Fuel Pump Kit

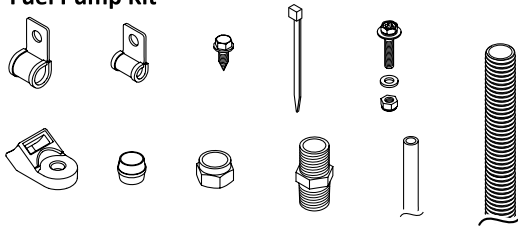

**4** Skin Mounting Kit

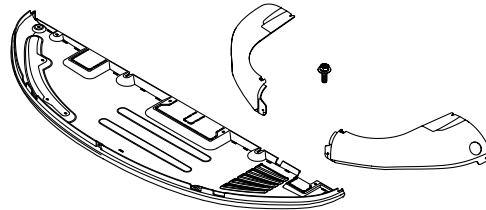

**5** Battery Mounting Kit

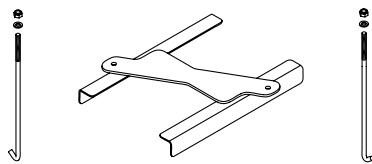

**6** UFLS Harness Kit

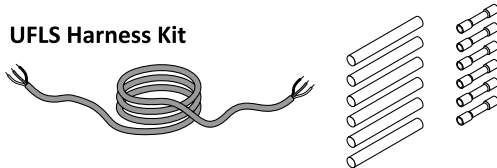

**7** Top Fairing Kit

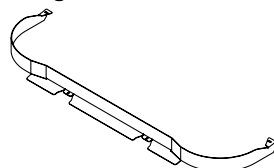

**8** (OPTION) SmartPower Kit

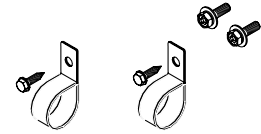

**9** Heat Shield & Mounting Screws

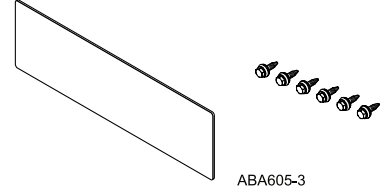

# Installation Components – RBC Applications

**1** Unit Mounting Kit

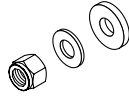

**2** Drain Tube Kit

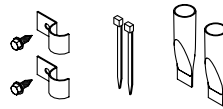

**3** Fuel Hardware Kit

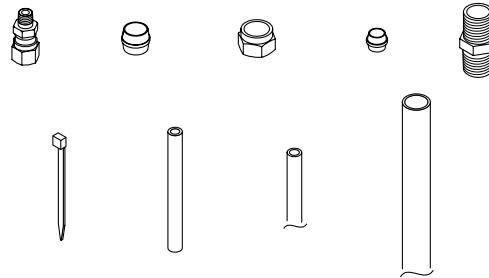

**4** Skin Mounting Kit

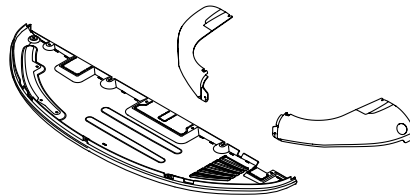

**5** Battery Mounting Kit

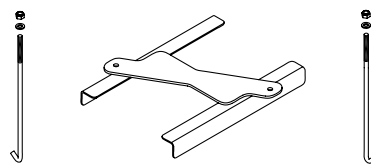

**6** Bottom Pan Grommets



**7** Heat Shield & Mounting Screws

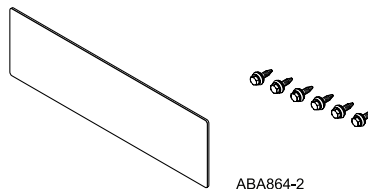

# Installation Components – DRC Applications

**1 Unit Mounting Kit**

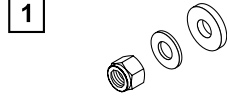

**2 Drain Tube Kit**

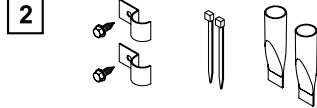

**3 Fuel Hardware Kit**

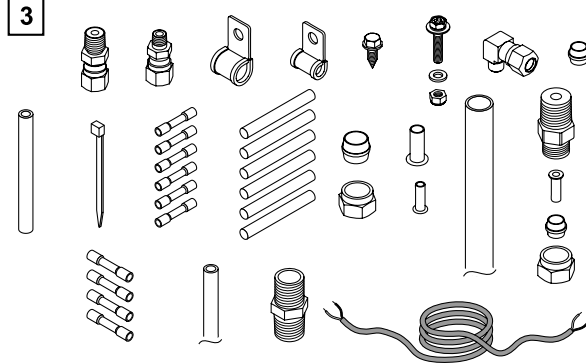

**4 Skin Mounting Kit**

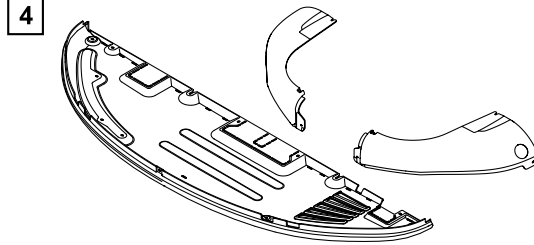

**5 UFLS Harness Kit**

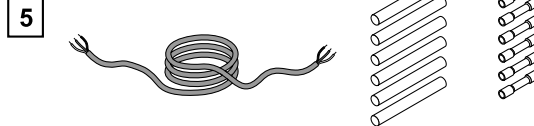

**6 Battery Mounting Kit**

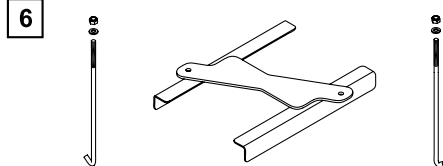

**7 Bottom Pan Grommet Kit**



**8 Heat Shield & Mounting Screws**

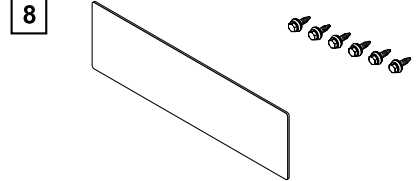

**9 Exhaust Tube Extension Components**

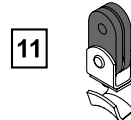
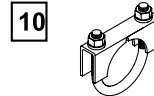
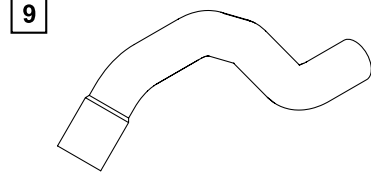

CAUTION: Hot Surface  
 ATTENTION: Surface Chaude  
 ACHTUNG: Heiße Oberfläche  
 ATTENZIONE: Superficie calda  
 ATENÇÃO: Superfície Caliente

ABA865-2

## Unpacking the Unit

### ⚠ WARNING

#### Risk of Injury!

Thermo King requires a 2 point lifting bar to safely lift and install units. A lifting bar can be made from the drawings provided using ASTM A514 Grade B Steel Plate (UNS K11630).

### ⚠ WARNING

#### Risk of Injury!

Use only locking hooks to safely lift the unit. Failure to use locking hooks could result in severe damage to the equipment, void the warranty, or cause personal injury or death.

**Note:** A lifting bar can be made from the drawings shown ("[Lifting Bar Dimensions](#)," p. 26) using ASTM A514 Grade B Steel Plate (UNS K11630).

Units are shipped attached to disposable wooden pallet and wrapped with protective cardboard and plastic stretch wrap.

**Note:** To avoid unnecessary damage to your unit, place the crated unit near the trailer prior to its removal.

**Important:** DO NOT use a sharp knife to remove the stretch wrap or cardboard wrap as damage to the exterior of the unit will result.

1. Carefully remove plastic stretch wrap from unit.
2. Carefully remove the top cardboard cover.
3. Carefully remove the outer cardboard wrap.
4. Remove installation kit boxes, bottom panel, and any other loose components from rear of unit.
5. Install two forged eyebolts into the top corners of the unit and attach the 2 point lifting bar with locking hooks to the eyebolts. Raise unit only enough to remove slack from lifting bar chains.
6. Remove hardware holding unit to wooden pallet.
7. Unit is now ready for installation.

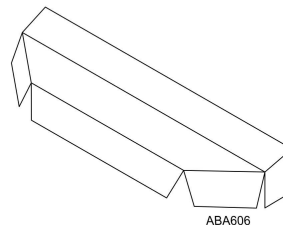
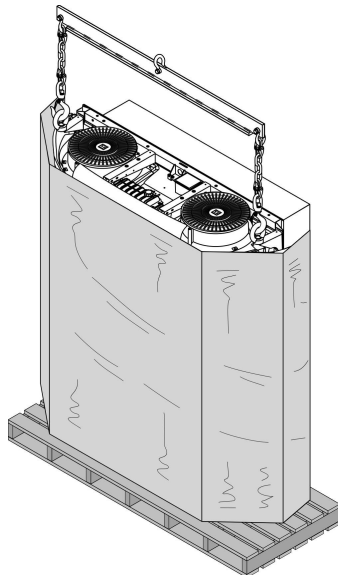



# Installing the Heat Shield

**Note:** Heat shield and screws can be found loosely attached to the rear of the unit with band wraps.

The supplied heat shield must be installed onto the front outside wall of the trailer prior to unit installation. The shield should be positioned approximately 76.2 mm (3.00 in.) down from the cutout and centered horizontally as shown.

1. Thoroughly clean the area shown with isopropyl alcohol to remove dirt, grease, wax, etc.
2. Starting at the top of the shield, peel approximately 25.4 mm (1.00 in.) of the backing liner from the shield, place shield onto trailer wall and progressively remove liner downward while applying pressure to the foil.
3. Once shield is installed, apply pressure to the remove wrinkles.  
**Note:** Any remaining wrinkles have no effect on performance.
4. Install provided sealing screws at each corner and top and bottom center of the shield.
5. The unit is now ready to be installed.

## FRONT VIEW

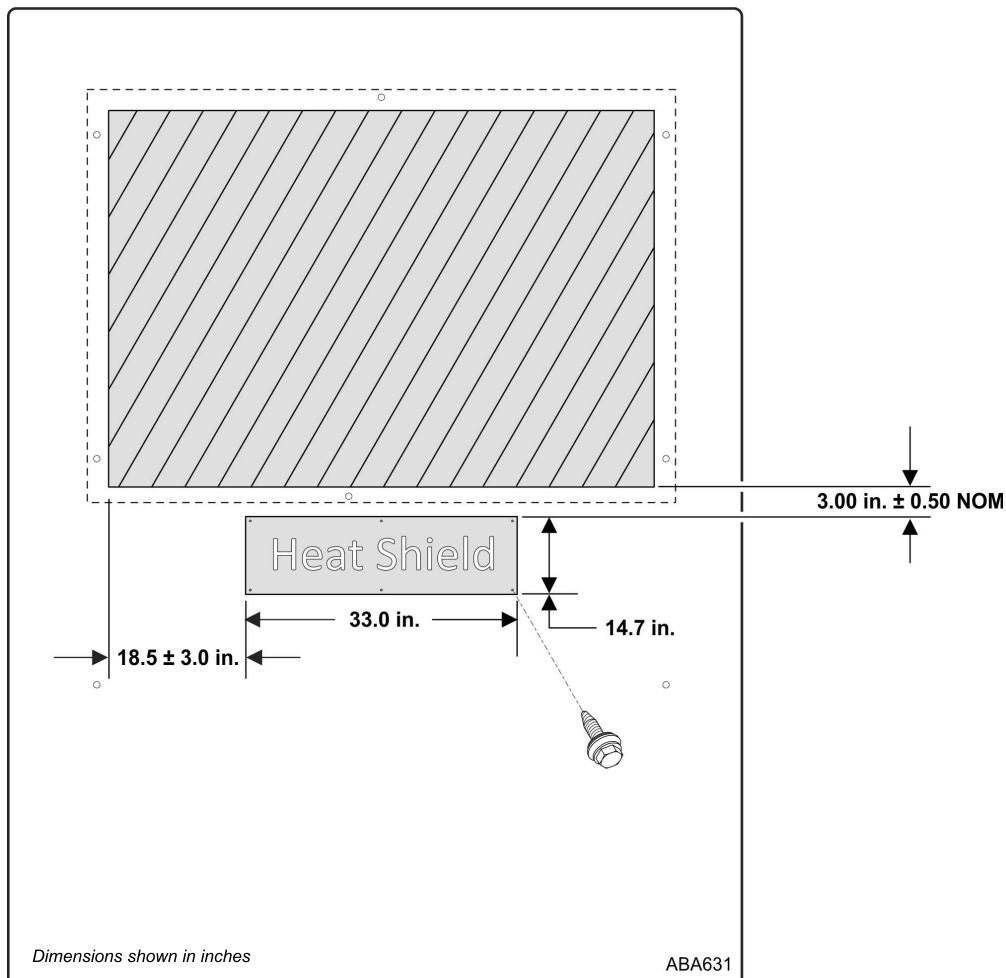

## Installing the Unit

### **⚠ WARNING**

#### **Equipment Damage and Risk of Injury!**

Do not use a forklift to install the unit. This could result in severe damage to equipment, void the warranty, or cause personal injury or death.

### **⚠ WARNING**

#### **Risk of Injury!**

Thermo King requires a 2 point lifting bar to safely lift and install units. A lifting bar can be made from the drawings provided using ASTM A514 Grade B Steel Plate (UNS K11630).

### **⚠ WARNING**

#### **Risk of Injury!**

Use only locking hooks to safely lift the unit. Failure to use locking hooks could result in severe damage to the equipment, void the warranty, or cause personal injury or death.

*Note: A lifting bar can be made from the drawings shown ("[Lifting Bar Dimensions](#)," p. 26) using ASTM A514 Grade B Steel Plate (UNS K11630).*

## Unit Installation

*Note: Refer to the illustration on the following page.*

1. Raise unit up to the trailer opening and position onto the mounting bolts.
2. Attach thick washer, standard washer, and elastic stop nuts provided in the installation kit. Torque to 82 N•m (60 ft. lbs.).

## Access to Mounting Bolts

*Note: Refer to the illustration on the following page — Detail II.*

- a. Top side mounting hole through the hinged roadside grille.
- b. Center side mounting hole through hinged roadside grille.
- c. Lower side mounting hole through hinged roadside panel, behind hinged control box.
- d. Center side mounting hole through hinged lower curbside door.
- e. Lower side mounting hole through hinged curbside panel.
- f. Center side mounting hole through hinged curbside grille.
- g. Top side mounting hole through hinged curbside grille.
- h. Top center mounting hole from top of the unit.

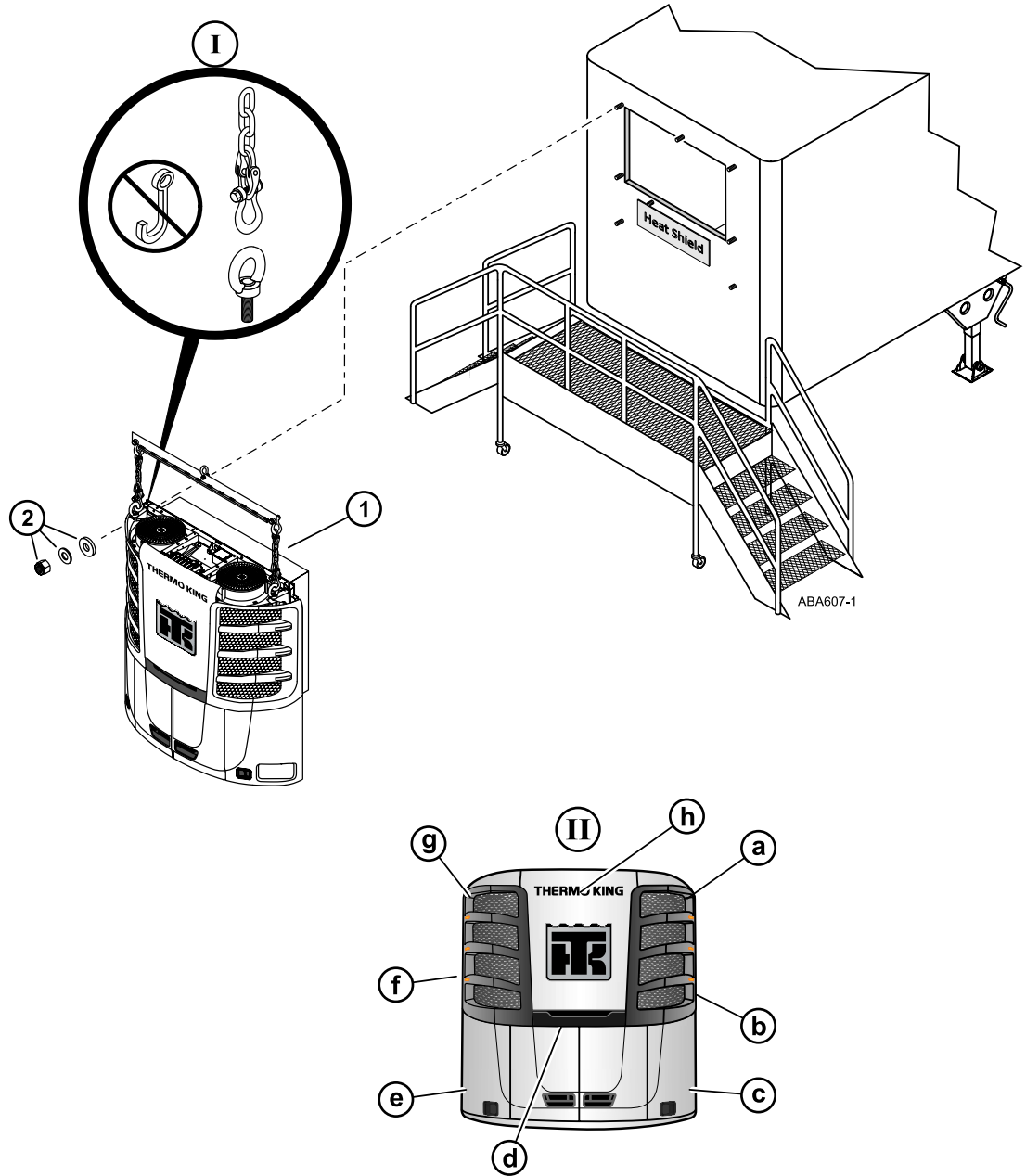

# Installing the Drain Hoses and Coolant Overflow Hose – Trailer Applications

## Evaporator Drain and Overflow Hose Installation

1. Evaporator drain hoses should run straight down the trailer wall from each side of the unit with no kinks or bends.
2. Cut off excess hose and attach check valves with supplied band wraps.
3. Secure each hose to trailer wall with two clamps and screws as shown.

**Important:** Upper clamp location varies by individual application while lower clamps should be installed 127 mm (5.00 in.) up from the bottom of the drain valves and not be so tight as to restrict water drainage.

4. Coolant overflow hose should run straight down the wall with no kinks or bends.
5. Secure the overflow hose to the evaporator drain hose with supplied bandwraps as shown

**Important:** The band wraps must not be so tight as to restrict water drainage.

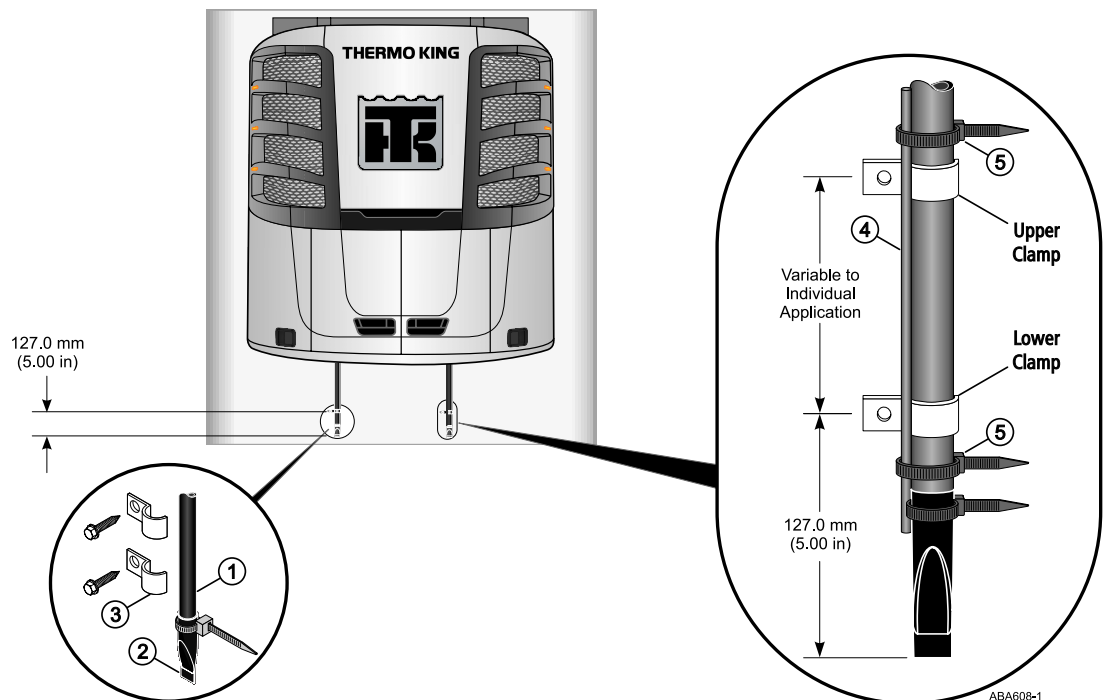

# Installing Drain Hoses and Coolant Overflow Hose – DRC and RBC Applications

## Drain and Overflow Hose Installation

**Note:** The drain hoses will need to be routed off to one side, behind the fuel tank, and down the front wall.

1. Evaporator drain hoses should run down from the unit with no kinks or sharp bends.
2. Secure each hose to the front wall with clamps and screws as shown.
3. Cut off excess hose and attach check valves with supplied bandwraps.

**Important:** Upper clamp location varies by individual application while lower clamps should be installed 127 mm (5.00 in.) up from the bottom of the drain valves and not so tight as to restrict water drainage.

4. Coolant overflow hose should run straight down the wall with no kinks or bends.
5. Secure the overflow hose to the evaporator drain hose with supplied bandwraps as shown.

**Important:** The band wraps must not be so tight as to restrict water drainage.

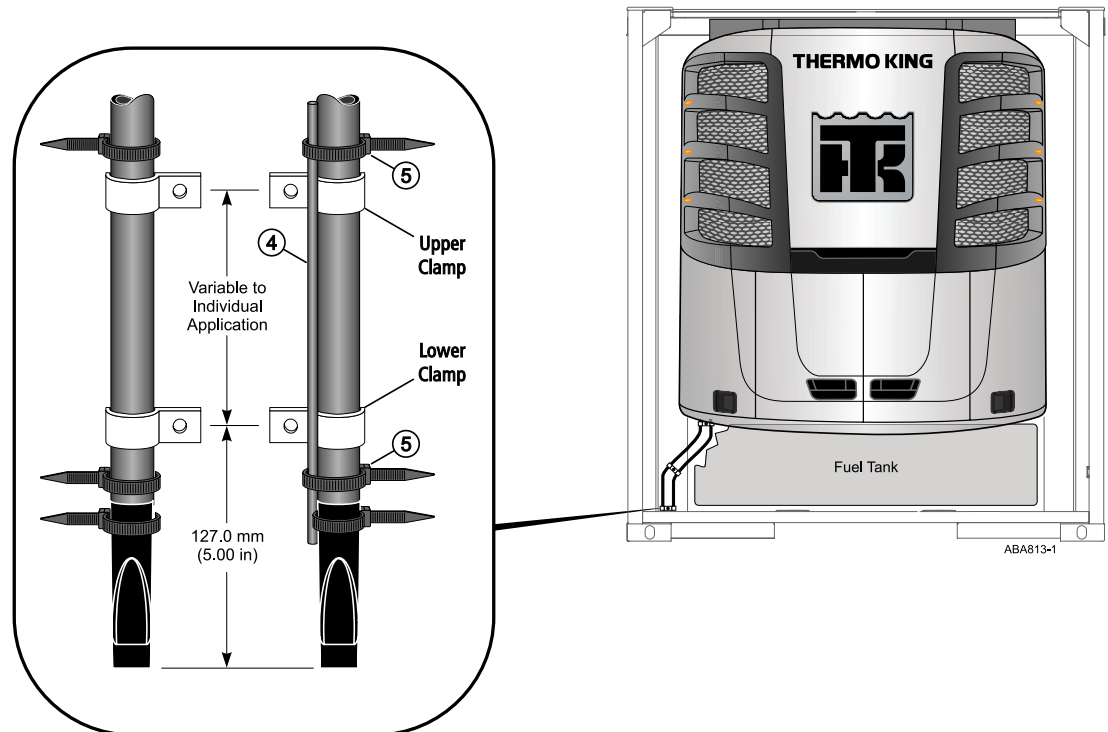

# Installing the Fuel Lines – Trailer Applications

## Important Installation Requirements

### **⚠ DANGER**

#### **Fire Hazard!**

Leaking fuel lines could cause a fire resulting in death or serious injury. All fuel line fittings must be tight and leak free.

### **⚠ DANGER**

#### **Fire Hazard!**

Do not route fuel lines with battery cables or electrical wires, as this could cause a fire.

**DETAIL I** - Fuel lines should be routed in a protective housing with no kinks or sharp bends. Rubber grommets must be used when routing fuel lines through holes in metal.

**DETAIL II** - Secure all fuel lines with provided clamps.

**DETAIL III** - Both the fuel supply and the fuel return lines must be 25.4 (1.00 in.) from bottom of tank and the ends cut at 45 degree angle.

## Fuel System Fittings

**Important:** Using the wrong fuel system fittings may void your engine warranty! All Thermo King supplied fuel line fittings (except fuel line connector) are nickel plated brass for Precedent units.

*DO NOT use fuel fittings (main body) made of brass, copper, zinc, zinc plated or galvanized steel where it would make direct contact with flowing diesel fuel. Diesel fuel flowing through these types of fittings allows those metals to leach into the fuel forming deposits on the injector tips which fouls them prematurely.*

*Fuel fitting nuts, compression sleeves, and fuel line connectors made of brass are acceptable because diesel fuel does not flow across their surfaces.*

*Do not use PTFE (Polytetrafluoroethylene) thread sealing tape on the fuel fittings in a Precedent unit. PTFE tape may allow strands into the fuel system that could plug up the tight clearance fuel injectors causing failures.*

*Always use two wrenches (where applicable) when tightening fuel line fittings to help prevent stripping threads.*

## Fuel Line Installation

**Important:** The band wrap, anchor tie and conduit provided in the installation kit are to be used to secure the fuel lines to the rear of the frame. The fuel lines must also be secured to the frame and the fuel pump bracket with the supplied clamps as shown.

1. Route 3/8" fuel supply line from the fuel pump **INLET** fitting down to the fuel tank.
  - a. Install 3/8" pass through fitting onto the fuel tank **SUPPLY** tube fitting.
  - b. Cut end of 3/8" supply line at 45 degrees and install sleeve and nut.
  - c. Insert line into supply tube until it bottoms out, then pull line up 25.4 mm (1.00 in.) and tighten nut securely.
2. Route 3/8" fuel return line from fuel filter down to the fuel tank **RETURN** tube fitting.
  - a. Install 3/8" pass through fitting onto the fuel tank **RETURN** tube fitting.
  - b. Cut end of return line at 45 degrees and install sleeve and nut.
  - c. Insert line into return tube until it bottoms out, then pull line up 25.4 mm (1.00 in.) and tighten nut securely.
3. Remove plastic cap from the fuel tank air vent and point the outlet to the rear of the trailer.

**IMPORTANT:** Factory installed fuel tank air vent must be in place and functional for Thermo King unit's fuel system to operate correctly and for the fuel tank to remain in compliance with Federal Motor Carrier Safety Administration specifications (title 49, paragraph 393.67). A plugged or restricted fuel tank air vent can result in premature damage to the fuel pump and could also cause severe damage to the fuel tank. **NEVER** remove or install any other component in place of the fuel tank air vent.

**Note:** It is important not to allow the unit to run out of fuel during the engine break-in period. Add a sufficient amount of fuel (approximately 20 gallons) to allow the unit to run for 8 to 12 hours during engine break-in and pre-delivery procedures.

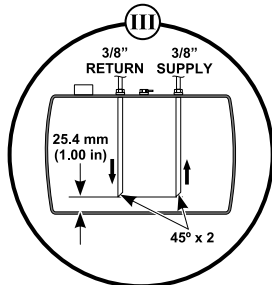
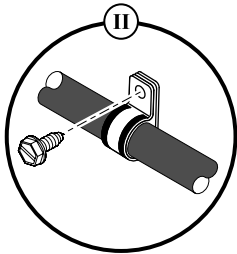
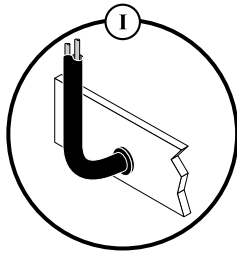

### EMI 3,000 / EMI Severe Duty Filter

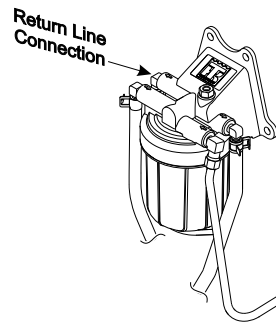

### EMI 3,000 / EMI Severe Duty Filter w/Heater

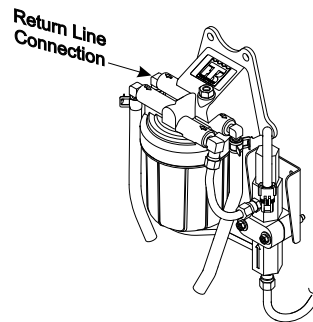

ABA639-1

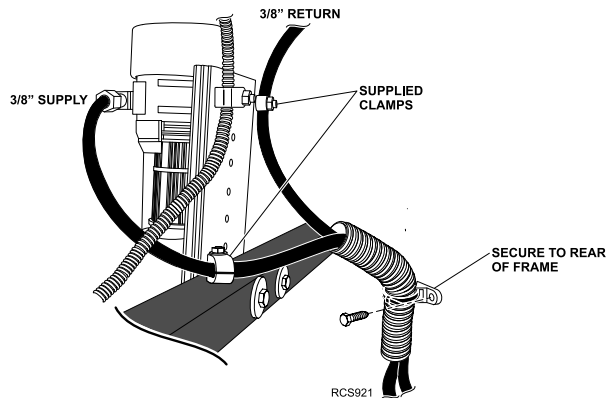

# Installing the UFLS Harness – Trailer Applications

## “Solid State” Ultrasonic Fuel Level Sensor (UFLS)

**Important:** All electrical connections of the UFLS harness must be made with the supplied crimp and solder style connectors with separate heat shrink tubing. **DO NOT** burn the heat shrink. If the heat shrink is burnt, charred, or has bubbles from overheating, the wire connections must be removed and redone correctly.

## Interconnect Harness Installation and Routing

**⚠ DANGER**

**Fire Hazard!**  
Do not route electrical harness together with fuel lines as this could cause a fire resulting in death or serious injury.

**Note:** Refer to illustration on following page.

1. Attach the interconnect harness to the fuel sensor wires located inside the control box.

Connections inside Control Box
BLACK to FUELN-01
WHITE to FUEL-01
GREEN to 8F-01

- a. Slide supplied heat shrink tubing onto each wire and position them away from joint.
  - b. Connect each wire with wire connector and crimp securely.
  - c. Solder wires to wire connectors with a soldering gun.
  - d. Slide heat shrink tubing over each wire connector and applying heat with a heat gun.
  - e. Secure harness inside the control box with tie bands.
2. Route the harness to the fuel tank using the trailer’s harness conduit or chase to avoid interference with fifth wheel plate area.

## UFLS Harness Connections

**Note:** Refer to illustration on following page.

1. Cut the interconnect harness to length and splice wires to the fuel sensor’s leads.

Connections at Sensor
BLACK to BLACK
WHITE to YELLOW
GREEN to RED

- a. Slide supplied heat shrink tubing onto each wire and position them away from joint.
  - b. Connect each wire with wire connector and crimp securely.
  - c. Solder wires to wire connectors with a soldering gun.
  - d. Slide heat shrink tubing over each wire connector and applying heat with a heat gun.
2. Secure any exposed harness with clamps.

**Important:** This is a “Solid State” fuel level sensor and the SR-4 Controller must be programmed accordingly to enable the fuel level feature.



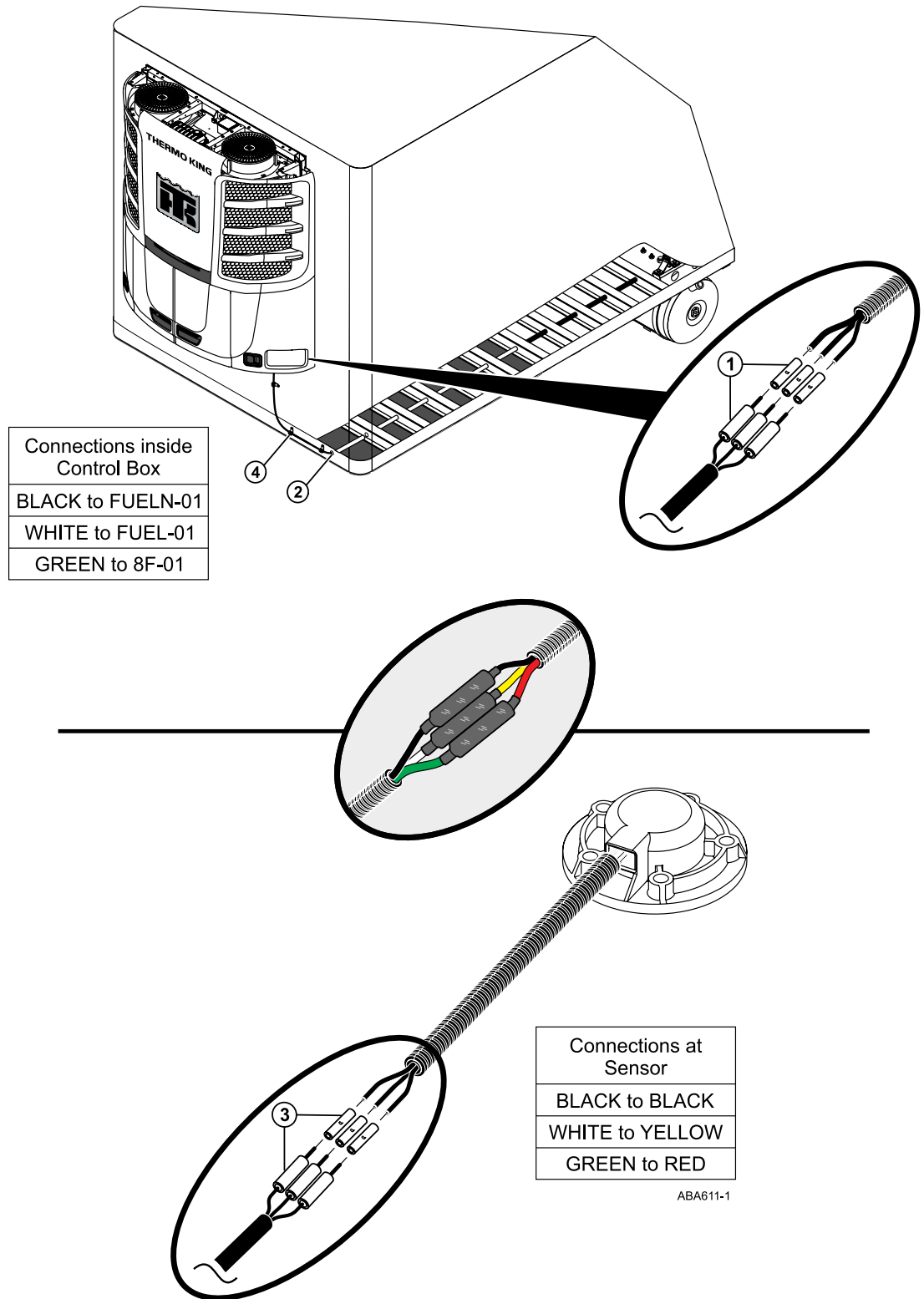

ABA611-1

# Installing the Float Style Fuel Level Sensor Harness – DRC and RBC Applications

*Note: For fuel tanks without Ultrasonic Fuel Level Sensor (UFLS).*

## Wire Routing and Connections

### **⚠ DANGER**

#### **Fire Hazard!**

**Do not route electrical harness together with fuel lines as this could cause a fire resulting in death or serious injury.**

*Note: Fuel level sensor harness 3-pin connector is located outside the control box. It can be found secured to other harnesses at rear of unit near frame mounted ground plate and behind the battery tray.*

*Important: The use of the supplied crimp and solder style connectors with separate heat shrink tubing is required when connecting the fuel level sensor wires.*

1. Locate the factory installed fuel level sensor harness with 3-pin connector.
  - a. Apply a light coating of Superlube (or equivalent) to the connector.
  - b. Connect the factory installed harness to the 6 ft. (1.8 m) fuel level sensor harness and route to fuel tank.
2. At the tank, cut the harness to length and connect the wires to the fuel level sensor wires (wires are not polarity sensitive) by:
  - a. Sliding supplied heat shrink tubing onto each wire and positioning them away from the joint.
  - b. Stripping the wire ends, inserting them into the wire connectors and crimping securely.
  - c. Soldering the wires to the connectors with a soldering gun.
  - d. Sliding the heat shrink tubing over the wire connectors and applying heat with a heat gun.
3. Use supplied bandwraps, clamps, and screws to secure the harness.

*Important: This is a "Float Style" fuel level sensor and the SR-4 Controller must be programmed accordingly to enable the fuel level feature.*

**Installing the Float Style Fuel Level Sensor Harness – DRC and RBC Applications**

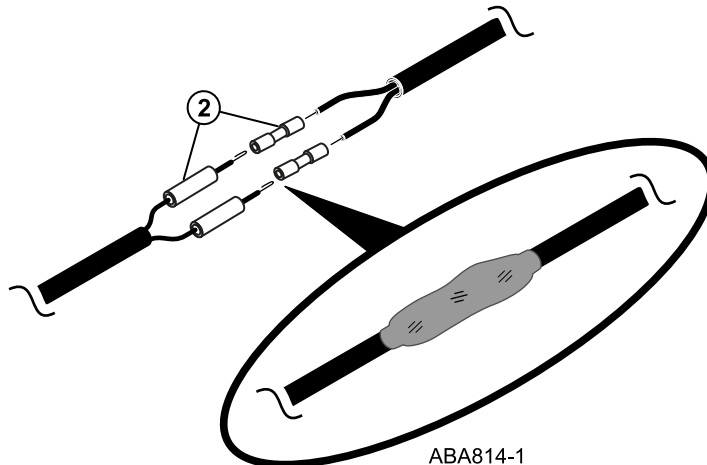
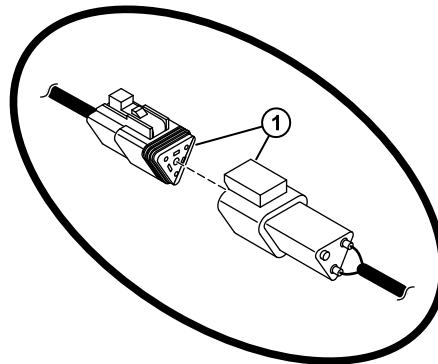
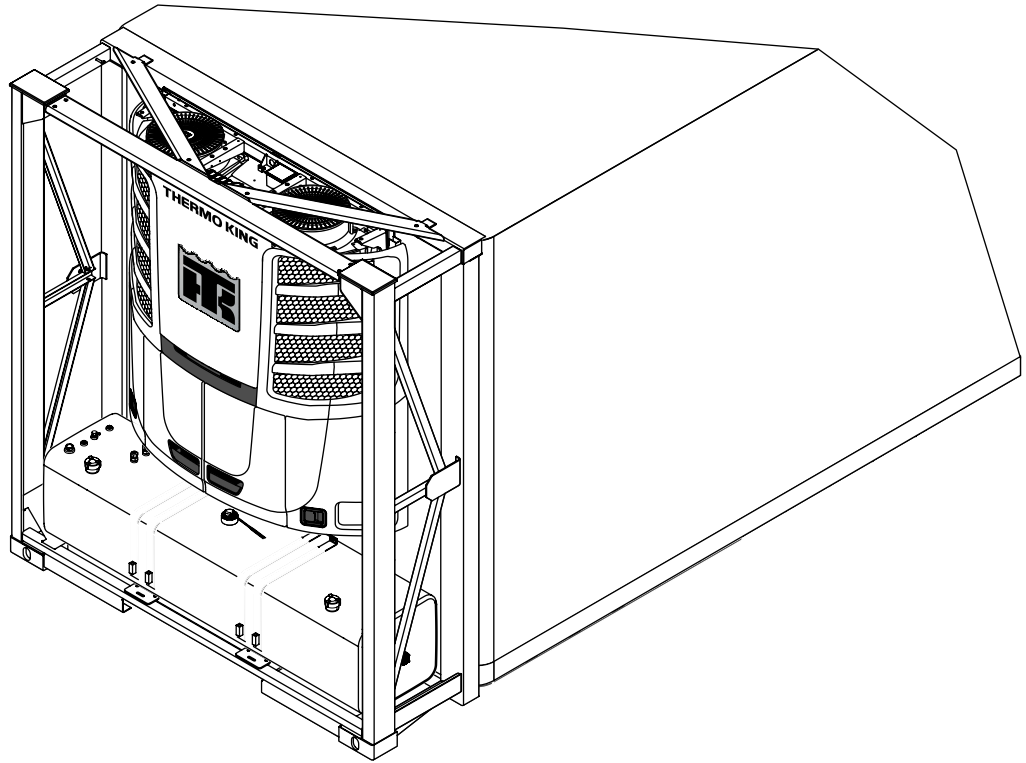

# Installing the Power Receptacle (Option) – Trailer Applications

## Power Receptacle Installation

**Note:** *Optional SmartPower units have the power receptacle and cable factory wired and secured inside the unit with tie bands for shipment.*

1. Remove tie bands securing receptacle to unit.
  - a. Attach receptacle bracket under the roadside of the unit with the two supplied screws.
  - b. Securely tighten hardware.
2. Secure cable under the unit to the trailer wall with supplied cable clamps and screws.

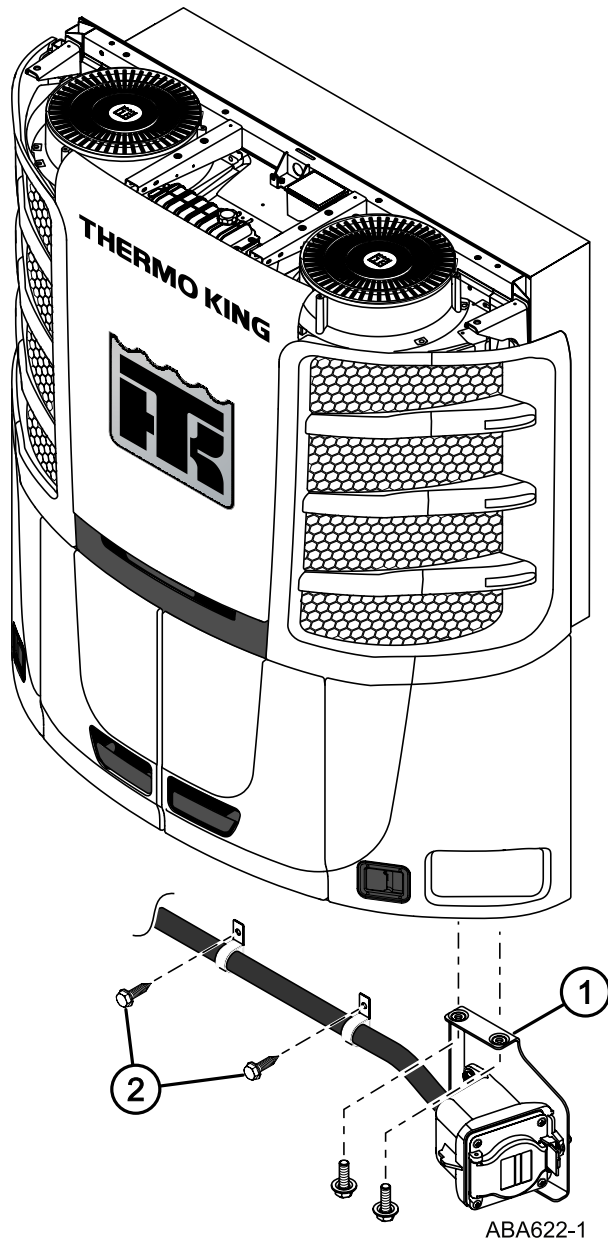

## Installing the LED Clearance Lighting (Option) – Trailer Applications

### Installation

1. Locate the following:
  - LED extension harness bundled and secured under the unit.
  - Fuse holder and butt splice connector shipped with the unit.
2. Route the LED extension harness to the trailer's OEM lighting connector.
3. Allow enough wire to provide a drip loop and cut LED extension harness to proper length.
4. **POWER WIRE** - Install the fuse holder to the power wire (**LEDP-07**) with the butt splice connector.
  - Connect the power wire with the fuse holder to the **BROWN** wire on the trailer's OEM lighting connector.
5. **GROUND WIRE** - Connect the ground wire (**LEDN-07**) to the **WHITE** wire on the trailer's OEM lighting connector.
6. Provide a drip loop and secure wires with a clamp.

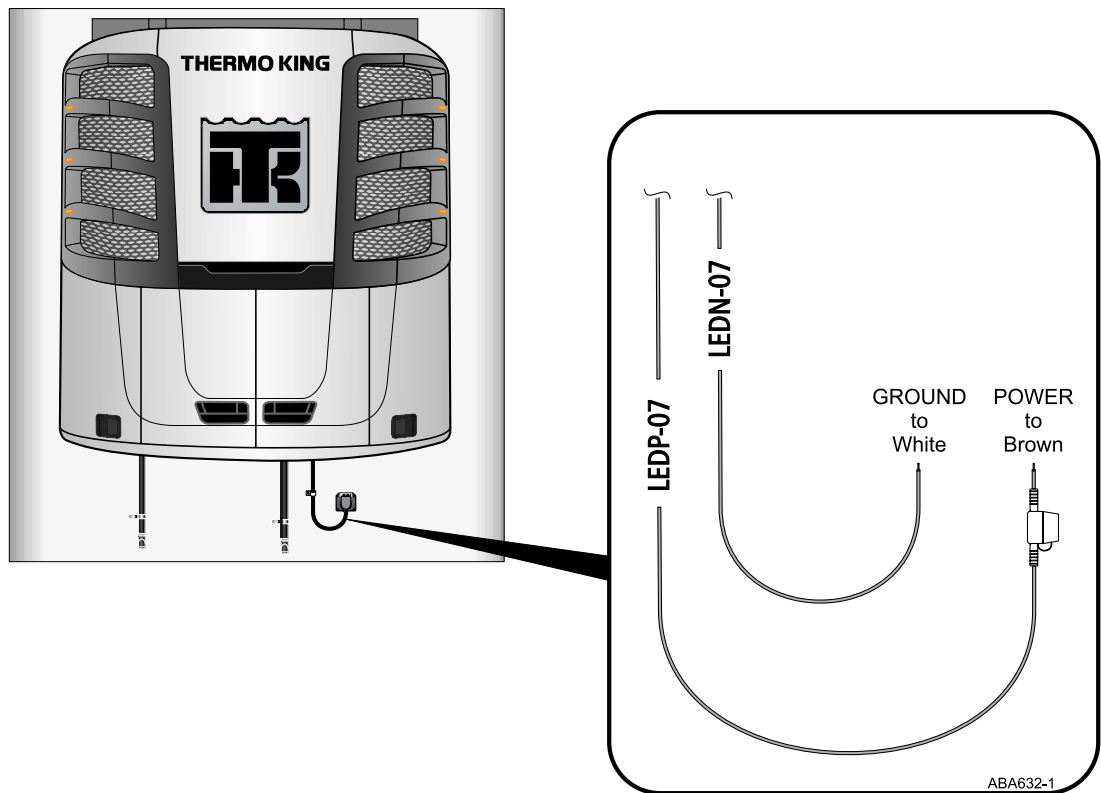

# Installing the Battery

## Important Battery Information

*Important:* See “Battery Installation and Cable Routing” (“Safety Precautions,” p. 6) for additional information.

### **⚠ WARNING**

#### **Hazard of Explosion!**

An improperly installed battery could result in a fire, explosion, or injury. A Thermo King approved battery must be installed and properly secured to the battery tray.

### **⚠ WARNING**

#### **Hazard of Explosion!**

Improperly installed battery cables could result in a fire, explosion, or injury. Battery cables must be installed, routed, and secured properly to prevent them from rubbing, chaffing, or making contact with hot, sharp, or rotating components.

*Note:* Thermo King units are designed for one 12 volt, group 31 battery. The battery must be suitable for deep cycling, heavy duty, and rated with a minimum of 95 amp/hr.

## Battery Installation

*Important:* Care should be taken to prevent direct metal contact to the battery’s positive post when installing the battery.

1. Open the roadside panel to access the control box.
  - a. Loosen the two bolts securing the control box in place.
  - b. Swing the control box away to gain access to the battery tray area.
2. Open the roadside door.
  - a. Pull the hinge pins and remove the door assembly from unit.
3. Locate the lower bracket directly in front of the battery tray.
  - a. Remove the two bolts and bracket from the frame.
4. Install the battery into the plastic liner.
5. Attach the **positive (+)** battery cable on the positive battery post and securely tighten.
6. Install the battery hold down rods and bracket.
  - a. Tighten the two battery hold down rods to 2.25 N•m (20 in -lbs.). **DO NOT over tighten as this may crack or distort the battery.**
7. Attach the **negative (-)** battery cable on the negative battery post and securely tighten.
8. Reinstall the bracket removed in Step 3 and securely tighten hardware.
9. Swing the control box assembly back into place and securely tighten the two screws.
10. Reinstall the roadside door back onto the hinges and securely close.

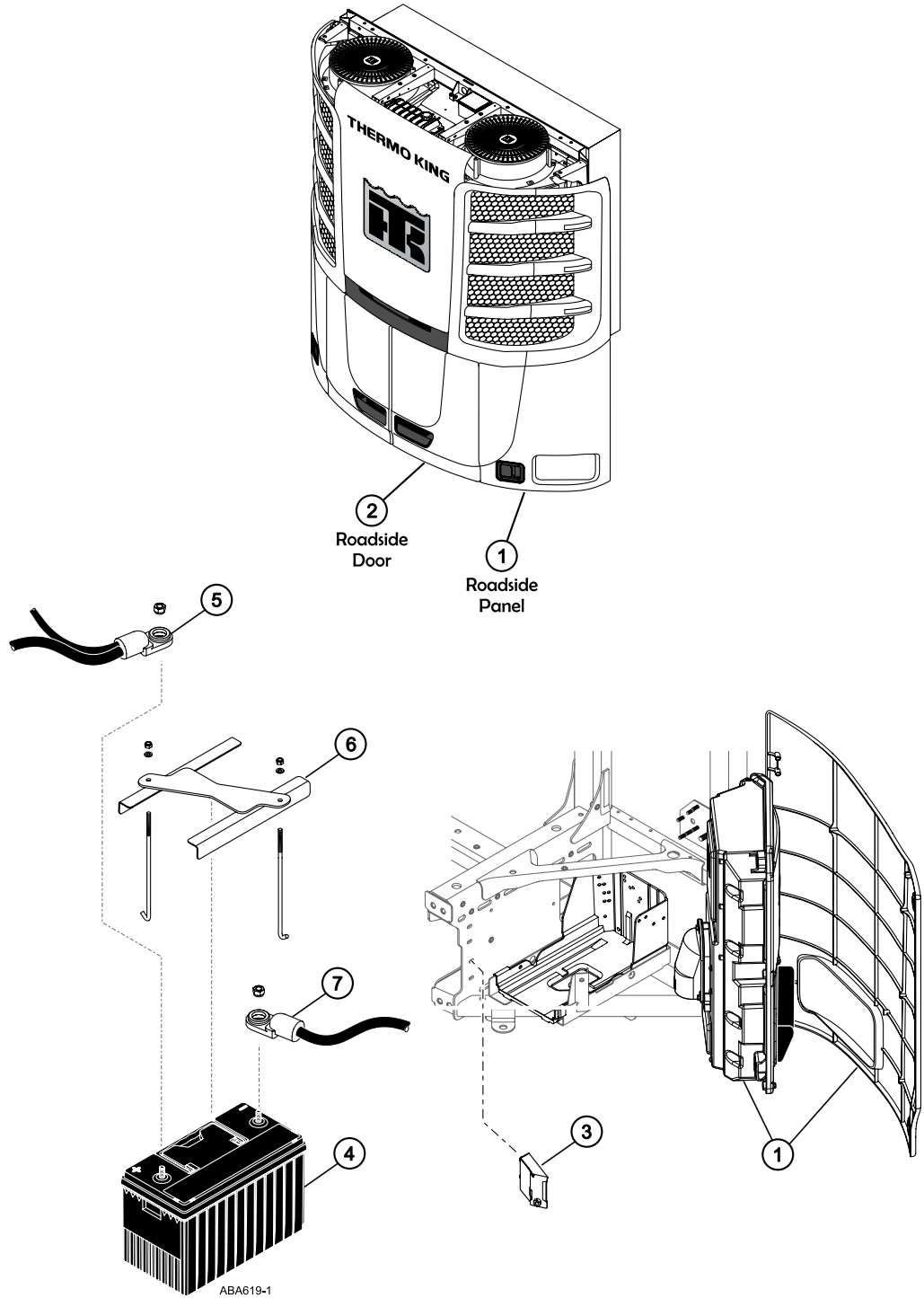

# Installing the Top Covers and Bottom Pan – Trailer Applications

## Important Fairing Information

**Note:** The top fairing increase the height of the unit by approximately 76 mm (3.00 in.). Tractor trailer height restrictions differ from state to state. The total height of the unit installed onto your particular trailer should not exceed these height restrictions. Remove the top fairing if it causes the unit to exceed these height restrictions.

## Top Covers

**Important:** Top covers must be positioned between condenser fan grille and fairing as shown in Detail A.

1. Open the top door along with the curbside and roadside grilles.
2. Remove the two M6 screws that secure the fairing to each condenser fan grille as shown in Detail A.
3. Place top covers onto unit.
  - a. Lift fairing up just enough so the top cover mounting holes are positioned under the fairing mounting tab,
  - b. Loosely reinstall the M6 screws back down through fairing, top cover and into condenser fan grille.
  - c. Install remaining M6 screws supplied in kit to secure top covers to threaded inserts on frame.
  - d. Use a T-30 Torx drive and tighten screws to 69 kg-cm (60 –in.lbs).

## Bottom Pan

4. Open the roadside and curbside panels and doors.
5. Install five (5) nut clips onto frame: three (3) in frame mounting tabs, and one (1) in the end of the frame channels as shown in Detail B.
  - a. Position bottom pan under unit, align the five (5) mounting holes with the frame mounting tabs with nut clips and loosely install the M6 screws and washers.
  - b. Loosely install one (1) M6 screw and washer through the front center pan lip and into the front frame tab insert.
  - c. Loosely install the remaining eight (8) M6 screws and washers.
  - d. Use a T-30 Torx drive and tighten screws to 69 kg-cm, (60 in-lbs).
6. Close and secure all doors, panels and grilles.



**Installing the Top Covers and Bottom Pan – Trailer Applications**

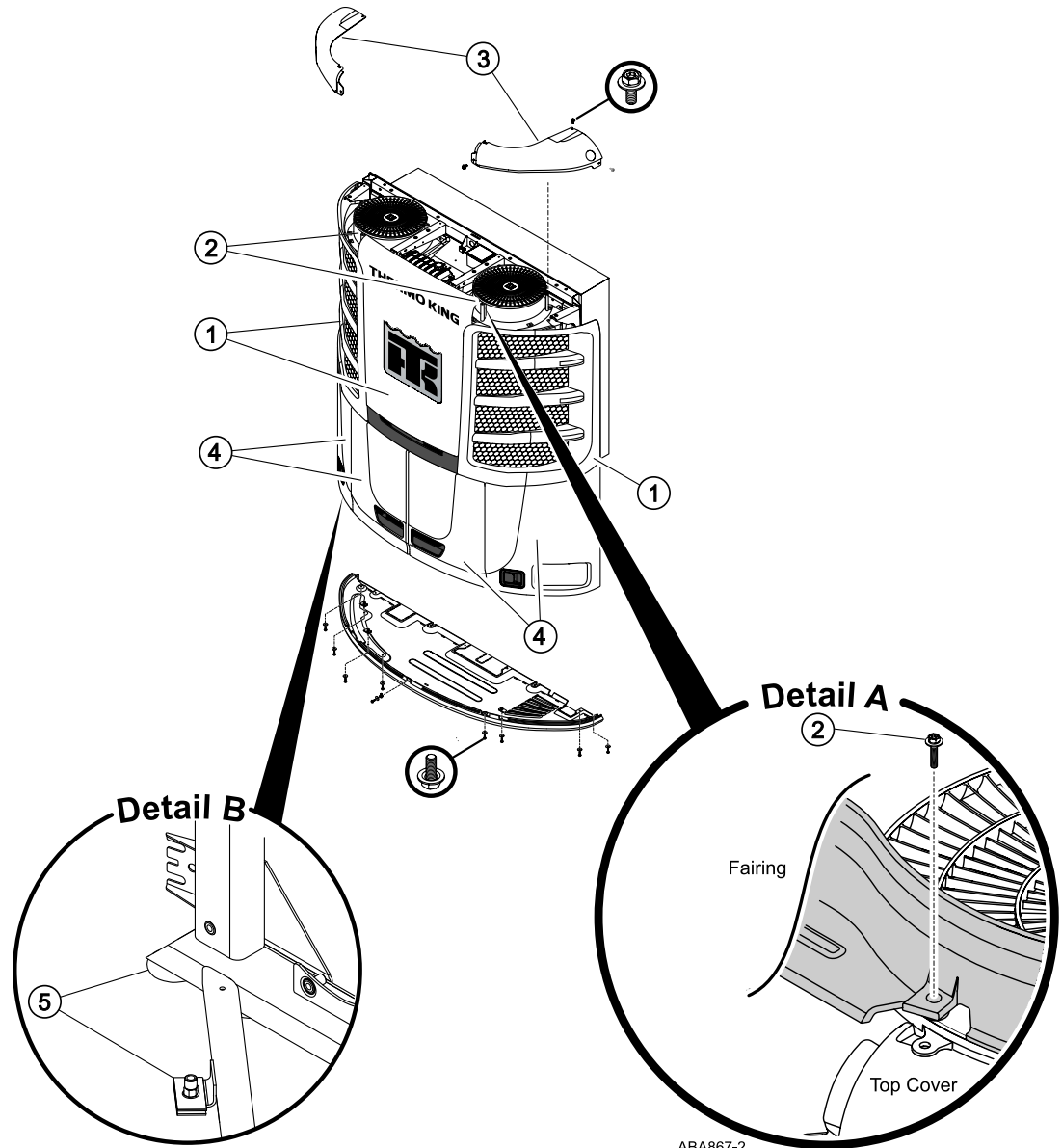

ABA867-2

# Installing the Top Covers and Bottom Pan – DRC and RBC Applications

## Top Covers

1. Open the top door along with the curbside and roadside grilles.
2. Remove the two M6 screws from each condenser fan grille as shown in Detail A.
3. Place top covers onto the unit with the upper mounting tabs positioned over the condenser grille mounting holes.
  - a. Loosely reinstall the M6 screws back down through the top cover mounting tabs and into the condenser fan grilles (**Detail A**).
  - b. Install remaining M6 screws supplied in kit to secure top covers to threaded inserts on the frame.
  - c. Use a T-30 Torx drive and tighten screws to 69 kg-cm (60 in-lbs.).

## Bottom Pan

4. Open the roadside and curbside panels and doors.
5. Before installing the bottom pan, two (2) 25.4 mm (1.00 in.) diameter holes will need to be drilled and grommets installed for the fuel lines. The hole location varies depending on your fuel tank. See [“Installing the Fuel Lines – DRC and RBC Applications,” p. 52.](#)
6. Install five (5) nut clips onto frame: three (3) in frame mounting tabs, and one (1) in the end of the frame channels as shown in Detail B.
  - a. Position bottom pan under unit, align the five (5) mounting holes with the frame mounting tabs with nut clips and loosely install the M6 screws and washers.
  - b. Loosely install one (1) M6 screw and washer through the front center pan lip and into the front frame tab insert. (**Detail B**)
  - c. Loosely install the remaining eight (8) M6 screws and washers.
  - d. Use a T-30 Torx drive and tighten screws to 69 kg-cm, (60 in-lbs).
7. Close and secure all doors, panels and grilles.

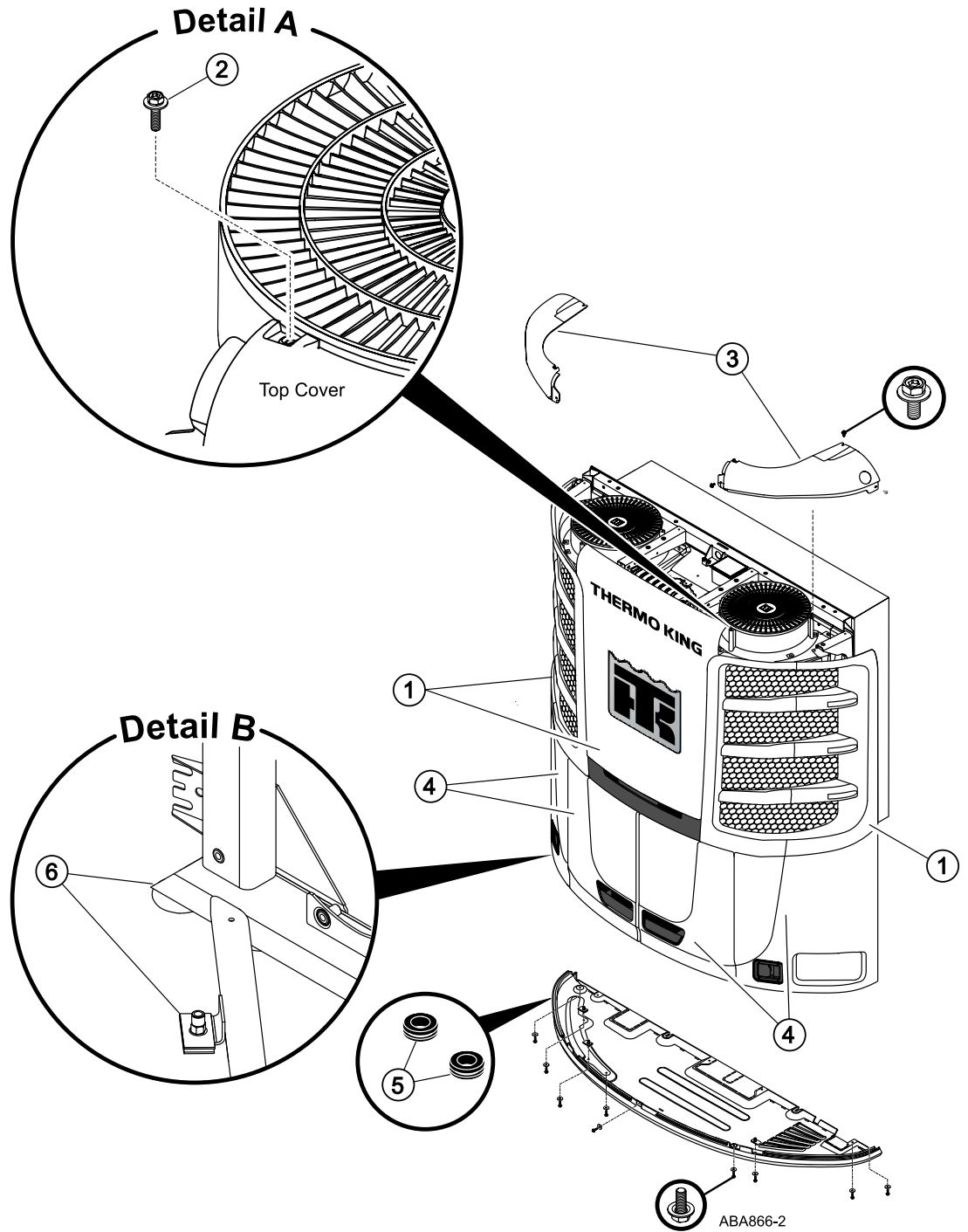

# Installing the Fuel Lines – DRC and RBC Applications

## Important Installation Requirements

### **⚠ DANGER**

#### **Fire Hazard!**

Leaking fuel lines could cause a fire resulting in death or serious injury. All fuel line fittings must be tight and leak free.

### **⚠ DANGER**

#### **Fire Hazard!**

Do not route fuel lines with battery cables or electrical wires, as this could cause a fire.

## Fuel System Fittings

**Important:** Using the wrong fuel system fittings may void your engine warranty! All Thermo King supplied fuel line fittings (except fuel line connector) are nickel plated brass for Precedent units.

*DO NOT use fuel fittings (main body) made of brass, copper, zinc, zinc plated or galvanized steel where it would make direct contact with flowing diesel fuel. Diesel fuel flowing through these types of fittings allows those metals to leach into the fuel forming deposits on the injector tips which fouls them prematurely.*

*Fuel fitting nuts, compression sleeves, and fuel line connectors made of brass are acceptable because diesel fuel does not flow across their surfaces.*

*Do not use PTFE (Polytetrafluoroethylene) thread sealing tape on the fuel fittings in a Precedent unit. PTFE tape may allow strands into the fuel system that could plug up the tight clearance fuel injectors causing failures.*

## Fuel Line Installation

**Note:** Before installing the bottom pan, two fuel line holes will need to be located, drilled and grommets installed. See Bottom Pan Rework drawing on next page.

**Important:** Use two wrenches (where applicable) when tightening fuel line fittings to help prevent stripping threads.

1. Route a 3/8" **FUEL SUPPLY** line from the fuel pump **INLET** fitting, down through the grommet in bottom pan (installed earlier), to the fuel tank.
  - a. Install a 3/8" pass through fitting onto the fuel tank's **SUPPLY** tube fitting.
  - b. Cut end of 3/8" fuel supply line at 45 degrees and install sleeve and nut.
  - c. Insert line all the way into supply tube until it bottoms out, then pull line up 25.4 mm (1.00 in.) and tighten nut securely.
2. Route a 1/4" **FUEL RETURN** line from fuel filter, down through the grommet in bottom pan (installed earlier), to the fuel tank fitting.
  - a. Cut the fuel return line straight/flush, attach fitting and install into the **RETURN** fitting on the tank (Detail A). Tighten fitting securely.
3. Remove plastic cap from the fuel tank air vent and point the outlet to the rear of the trailer.

**IMPORTANT:** The factory installed fuel tank air vent must be in place and functional for the Thermo King unit's fuel system to operate correctly and for the fuel tank to remain in compliance with Federal Motor Carrier Safety Administration specifications (title 49, paragraph 393.67). A plugged or restricted fuel tank air vent can result in premature damage to the fuel pump and could also cause severe damage to the fuel tank. **NEVER** remove or install any other component in place of the fuel tank air vent.

**Installing the Fuel Lines – DRC and RBC Applications**

**Note:** It is important not to allow the unit to run out of fuel during the engine break-in period. Add a sufficient amount of fuel (approximately 20 gallons) to allow the unit to run for 8 to 12 hours during engine break-in and pre-delivery procedures.

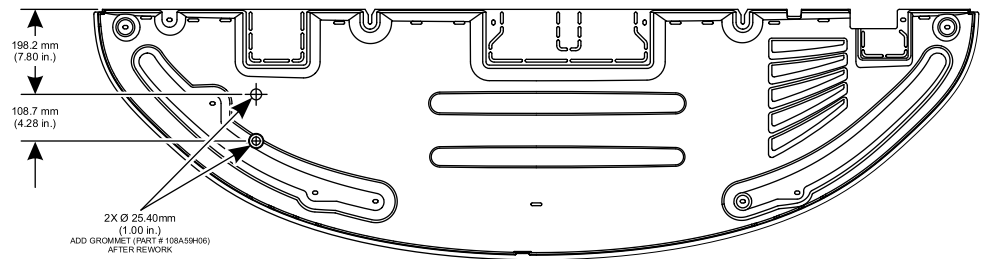
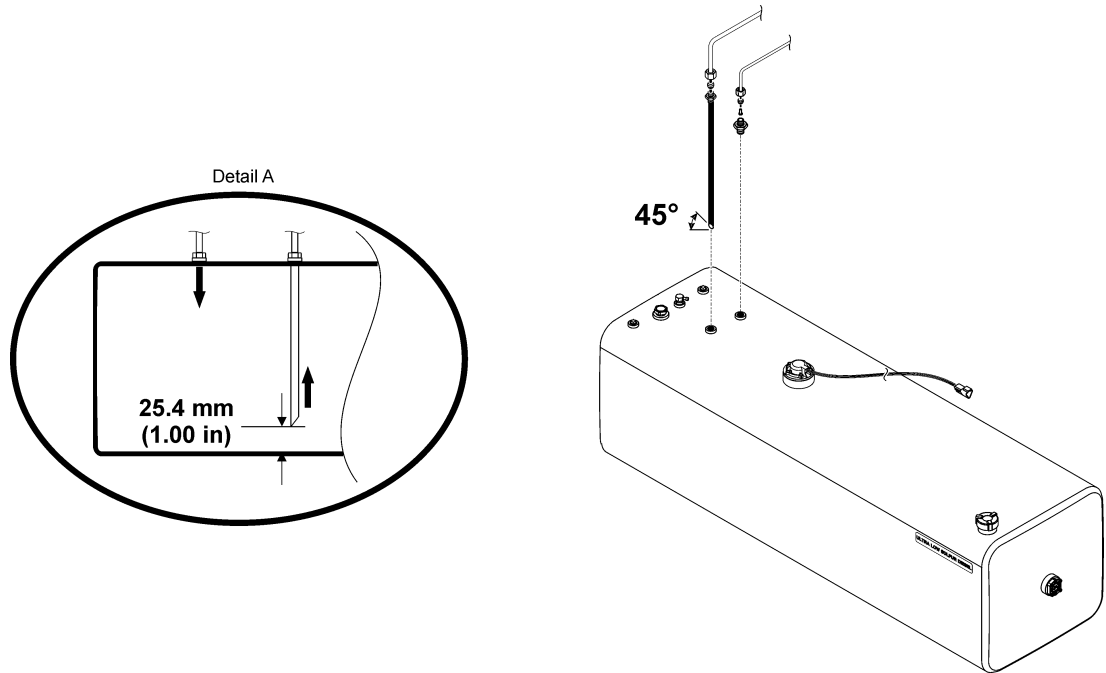

**BOTTOM PAN REWORK FOR 120 & 156 GALLON TANK  
S600RR DRC AND S700RR DRC**

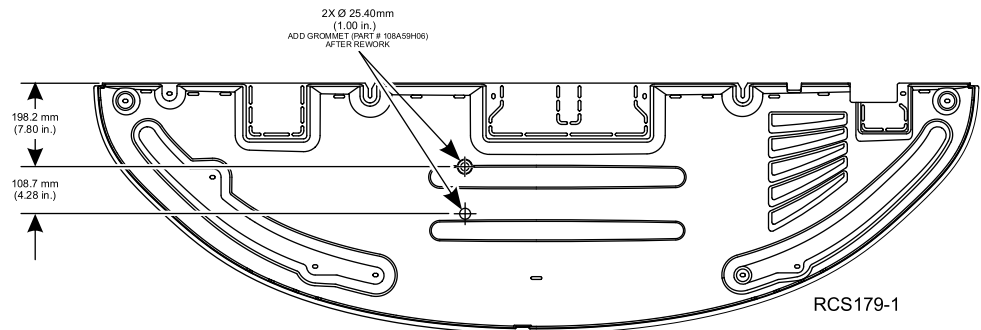

**BOTTOM PAN REWORK FOR 85 GALLON TANK  
S600RR DRC AND S700RR DRC**

## Installing the Exhaust Pipe Extension – DRC Applications Only

### Installation (containers with hanger support)

1. Install the exhaust hanger onto the hanger support located on the container.
2. Install the extension pipe onto the end of the exhaust pipe on the unit.
3. Install exhaust clamps and tighten securely.

### Installation (containers without hanger support)

**Note:** *If your container does not have an exhaust hanger support, one will need to be fabricated and installed.*

How to fabricate an exhaust hanger support:

1. Loosely install the exhaust pipe extension onto the end of the exhaust pipe on the unit.
2. Position the exhaust hanger and exhaust clamps as shown in the illustration.
3. Tighten the clamp to secure the extension pipe onto the unit.
4. Mark location of the exhaust hanger support on the container.
5. Weld the hanger support securely to the container.
6. Install the exhaust hanger onto the exhaust hanger support and tighten exhaust clamps securely.

### Nameplate Installation

Clean the surface of the container where the exhaust pipe outlet is located and attach the nameplate.

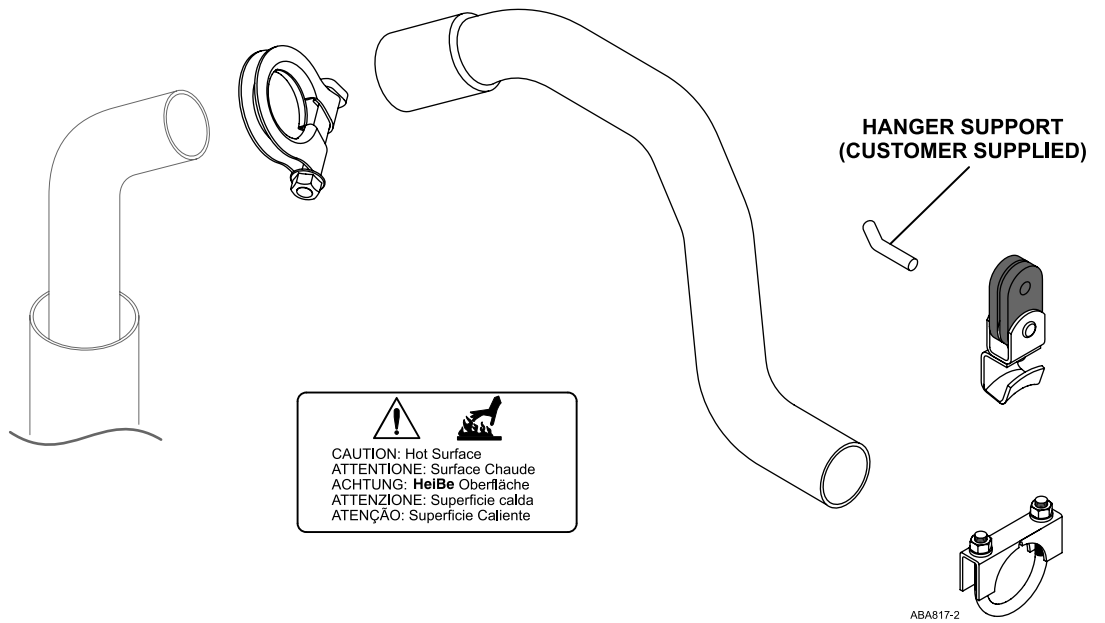
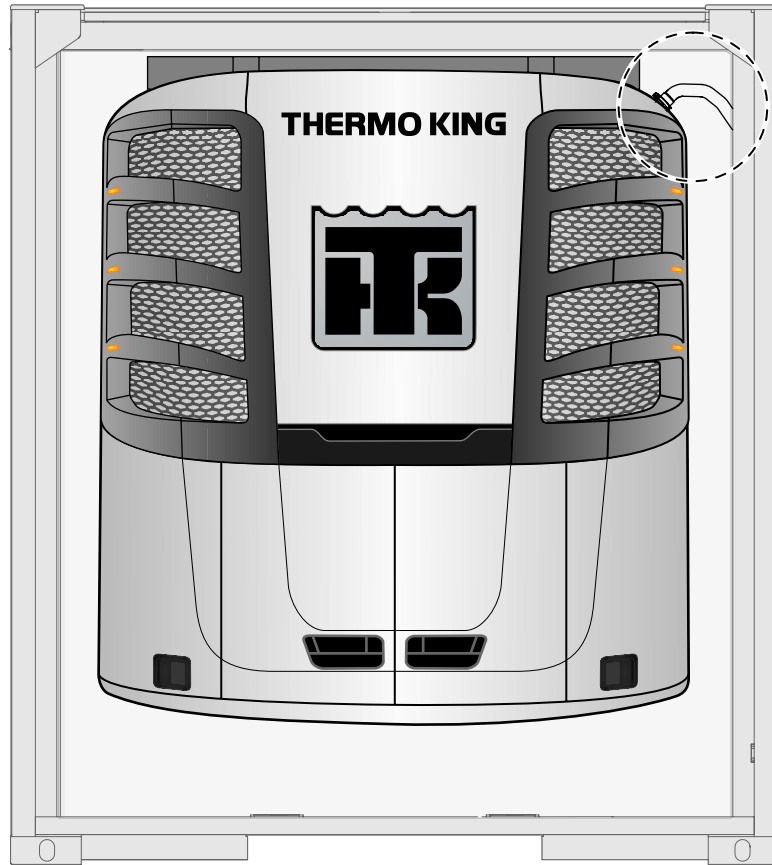

# Operating the Unit

**STOP - ONLY TRAINED AND QUALIFIED INDIVIDUALS SHOULD OPERATE THE UNIT. REFER TO YOUR PRECEDENT OPERATORS MANUAL FOR SPECIFIC DETAILS.**

## High Voltage Safety Precautions

**⚠ DANGER**

**Hazardous Voltage!**

Dangerous three phase AC electric power is present whenever the unit is operating in either Diesel Mode or Electric Mode and whenever the unit is connected to a source of external standby power. Voltages of this magnitude can be lethal. Exercise extreme caution when working on the unit.

## High Voltage Components

Various components on the Precedent unit operate using 220/3/60 or 460/3/60 high voltage and are identified by warning nameplates.

Additionally, all high voltage wiring is identified by ORANGE conduiting. Be aware of the locations of these components and understand that only certified and trained technicians should service them. Refer to the following page for locations of high voltage components.

## Unit Fan Operation Safety Precautions

**⚠ DANGER**

**Risk of Injury!**

The unit's Condenser fans and Evaporator fans may start automatically anytime the unit switch is ON and can cause serious injury. Switch unit to OFF before servicing.

## Condenser and Evaporator Fans

Be aware of the warning nameplates near the condenser fans and evaporator fans.

**High Voltage Warning Nameplates**

**Fan Warning Nameplate**

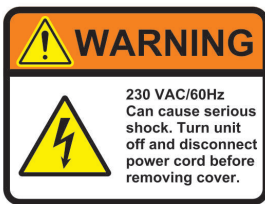

ABA623

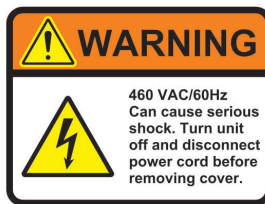

ABA624



ABA625



**High Voltage Component Locations**

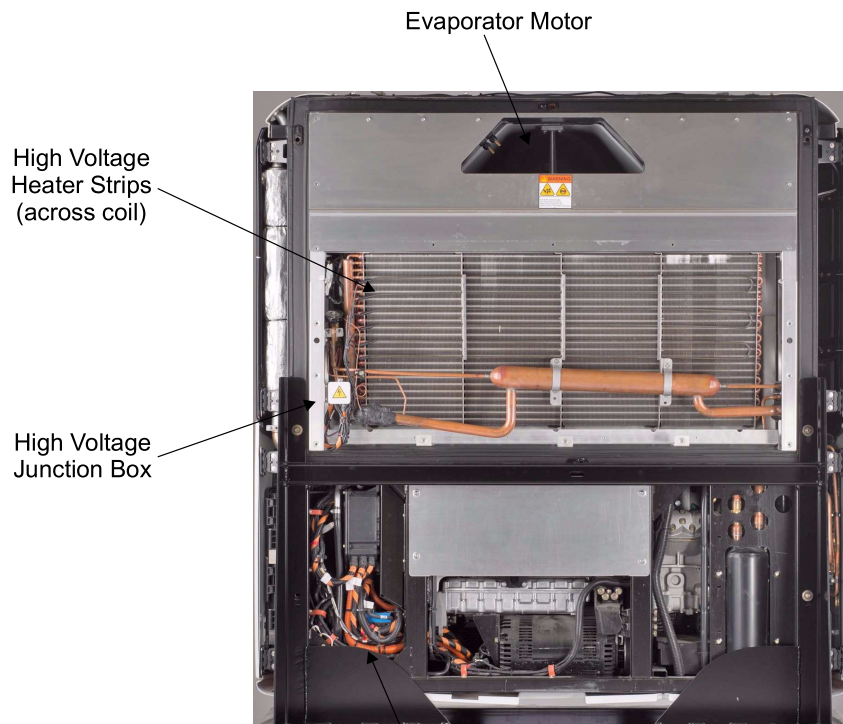
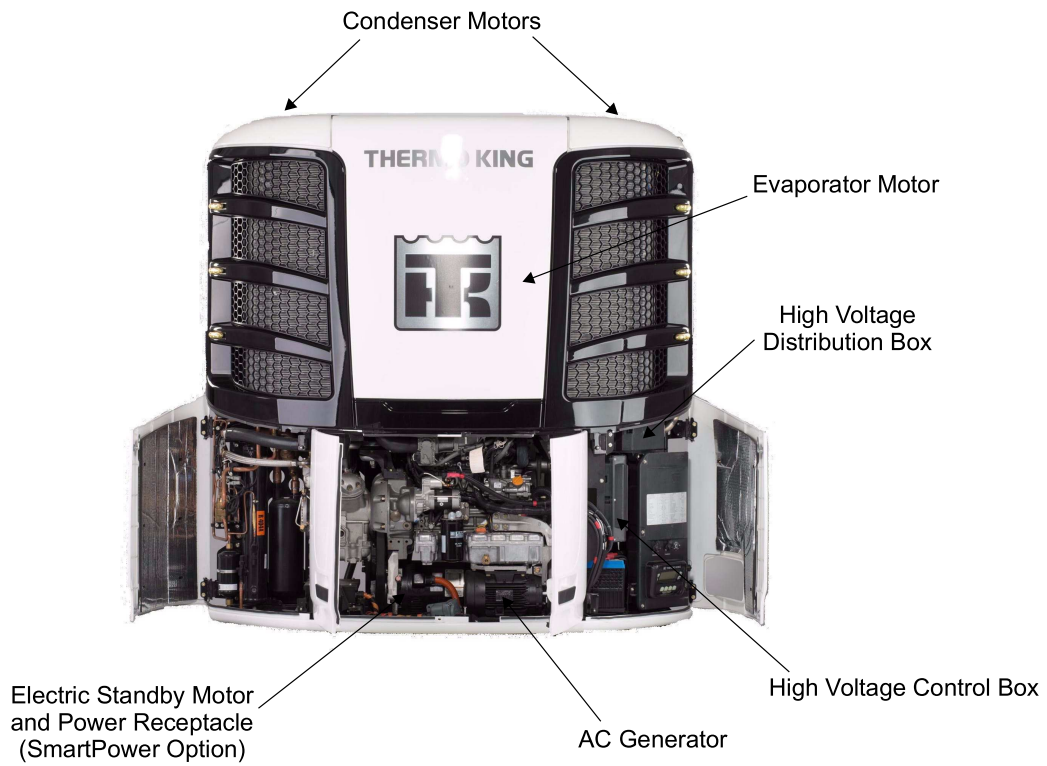

All high voltage wiring is identified by ORANGE conduiting

## Priming the Fuel Pump

The fuel pump needs to be primed and the fuel system bled of air before the diesel engine can be started for the first time.

There are two ways this can be done:

### **Recommended Procedure**

**Note:** *The fuel pump can be primed and fuel system bled of air (without starting the engine) by using the SR-4 Controller to operate only the fuel pump relay.*

1. Access **Maintenance Menu**
2. Access **Output Test**
3. Access **Run Relay** and PRESS Lock Key.
4. The fuel pump will begin to operate. Allow the pump to run for 5 minutes.
  - The diesel engine can now be started using the normal SR-4 Controller functions.

### **Alternative Procedure**

**Note:** *The fuel pump can be primed and fuel system bled of air by using the normal SR-4 Controller functions to start and run the unit.*

1. Use the SR-4 Controller to start the unit.
  - It may take a few attempts to start the diesel engine as the fuel pump primes itself, fills the fuel lines and filter, and automatically bleeds air from the system.
  - Once the unit starts, Alarm Code 20 (Engine Failed to Start) may be present and should be cleared.

# Programming the Controller

## Programming the SR-4 Controller for Fuel Level

*Note: These procedures can also be done through OptiSet™.*

### Programming Procedures

*Note: The Guarded Access Menu is not available if the engine is running.*

1. Turn off the engine.
2. Go to the Guarded Access Menu.
3. Scroll down and select the Unit Configuration.
4. Scroll down and select Fuel Level Sensor.  
The choices are: NONE, SOLID STATE, or FLOAT.
  - **USFLS STYLE** - scroll to SOLID STATE by pressing + key then YES key.
  - **FLOAT STYLE** - scroll to FLOAT by pressing + key then YES key.
  - Fuel Level Percent will now be in the gauge menu.
5. The unit is now programmed, press the exit key.

# UNIT CHECK LIST

## UNIT CHECK LIST

- BEFORE installing the unit, visually inspect it for any damage. If any damage appears, file claim with delivery carrier.
- Install the fuel tank, fuel lines and unit as outlined in the Thermo King Installation Manual.
- Add 20 gallons (minimum) of ultra-low sulfur diesel fuel to the tank.

## BEFORE STARTING THE UNIT

- Check battery and battery cable installation.
- Inspect fuel line routing checking for rubbing, chaffing or laying on hot surfaces.
- Visually inspect the unit for the following: Loose or improperly fitting bolts, brackets, hardware, hose connections, and hose routing.
- Inspect all wiring connections and routing.
- Check defrost drain hoses and kazoos.
- Check unit mounting hardware for tightness.
- Check compressor and engine mounts.
- Install refrigeration gauge manifold. (Multi-Temp units only)
- Check engine oil level.
- Check condenser and evaporator section for cleanliness and signs of refrigerant leaks.
- Check front bulkhead and air chute if equipped.

## MULTI-TEMP UNITS (REMOTE EVAPORATORS)

- Check evaporator(s) sections for cleanliness.
- Leak test interconnecting tubing.
- Check for damage, loose or missing bolts, and hardware on remote evaporator(s).
- Check for proper installation of drain tubes, drain kazoos and drain tube heater wires.
- Check for properly routed refrigerant lines wiring harnesses for remote evaporator(s). Check for properly routed harnesses for remote controller.
- Check for proper installation of remote evaporator guards if equipped.
- Check remote harness wiring plugs in the host evaporator.
- Check wiring, connections, and terminals in the remote evaporator(s).
- Check compartment bulk head(s) for proper fit if equipped.

## START AND RUN UNIT (On Multi-Temp units, start only the host unit)

- Check for proper oil pressure, coolant temperature, oil, fuel, or coolant leaks.
- Check alternator charge.
- Cycle the unit and ensure the unit functions in the correct modes and the mode indicators are working.
- Confirm engine speeds at normal engine running temperature. High Speed and Low Speed per maintenance manual. Check @70° F (21 C) box temperature and 70° F (21 C) ambient.
- Set for continuous run with thermostat set point at 32 F (0 C) and run the unit to 32 F (0 C).
- Observe and record refrigerant operating pressures in relation to ambient and box temperatures.
- Verify the readings above are correct for the conditions.
- When box reaches 32 F (0 C) check calibration of thermostat, thermometer and data logger.
- Run unit for 30 minutes at 32 F (0 C). During this period check for correct cycling.
- Reset thermostat to 50 F (10 C).

- Check throttling valve while in the heat cycle.
- Check operation of Modulation system if equipped.
- For Single Temp units perform a controlled check of the refrigerant level. For Multi-temps check the charge per multi-temp unit procedures.

**MULTI-TEMP UNITS**

- Install the compartment bulk head(s) if equipped.
- Check for correct rotation of remote evaporator fans.
- Check for correct cycling and operation of remote evaporator fans.

**ALL UNITS**

- Initiate and check defrost operation and termination. Check operation and adjustment of damper door and remote fans. Each zone on multi-temp units must be checked for proper operation.
- Set the unit for Cycle Sentry Operation.
- Check for proper operation of all door switches.
- Remove the compartment bulk head(s) if equipped.
- Set the unit for continuous run. **See important note below.** Choose a setpoint opposite of ambient temperature. Continue to run the unit with the trailer doors open. Operate the unit until 10 (minimum of 6) hours are shown on the engine run time hourmeter to verify complete break in of the engine.

**Important:** *Eco Pulldown Mode must be disabled to allow the engine to run at continuous high speed operation during engine break-in. The default setting is Eco Pulldown enabled. Refer to TT750 regarding disabling the Eco Pulldown Mode feature in Guarded Access Programmable Features Menu. After engine break-in is completed, return the programmable feature to Eco Pulldown enabled.*

- Run Pre-trip.

**ELECTRIC STANDBY OPERATIONAL CHECKS**

- Test AC electrical contacts and connections by connecting to AC power and running.
- Check for correct electric motor rotation.
- Check compressor clutch operation.
- Cycle thermostat and check for correct modes of operation.
- Power source not available to test AC.

**STOP UNIT**

- On multi-temp units, leak test interconnecting tubing.
- Check and readjust all belt tensions using TK belt gauge 204-1903 or equivalent frequency tool.
- Check for oil, fuel, coolant, refrigerant, and exhaust leaks.
- Check engine oil and coolant level.
- Check entire unit for loosened hardware and fittings.
- Check and adjust all skin, door and panels for correct alignment and operation.
- Complete the commissioning registration process.
- Release unit.



**THERMO KING**

Notes

---





Ingersoll Rand (NYSE: IR) advances the quality of life by creating comfortable, sustainable and efficient environments. Our people and our family of brands – including Club Car®, Ingersoll Rand®, Thermo King® and Trane® – work together to enhance the quality and comfort of air in homes and buildings; transport and protect food and perishables; and increase industrial productivity and efficiency. We are a global business committed to a world of sustainable progress and enduring results.



[ingersollrand.com](http://ingersollrand.com)

Ingersoll Rand has a policy of continuous product and product data improvements and reserves the right to change design and specifications without notice.

We are committed to using environmentally conscious print practices.